

CROWN

WWW.CROWN-TOOLS-EU.COM

PRODUCTS CATALOG

PROFESSIONAL POWER TOOLS AND EQUIPMENT



2024

MERIT LINK

Hardware tools and equipment

FOR THE ONES
WHO NEED
SOLUTIONS



MERIT LINK GROUP

Merit Link is an industrial internet group which combines **synergy on distribution, brands, R&D and production for hardware tools and equipments**.

Inspired by **"Tool for a better life"**, we create essential tools to make people's lives more convenient and enjoyable.

Merit Link is aiming to become an **international alliance service platform**, which can leverage the business scale by offering transparent customer oriented services to consumers, shop owners, distributors, brand operators and manufacturers.

The **headquarter of the group is located in Shanghai**, and are strategically surrounded by other operation centers, including **Design Center in Switzerland, Training, Logistic, R&D and manufacture Complex in Jinhua, Purchasing & Sales Center in South-west China**, etc.

Benefit from penetrating into market around "the Silk Road Economic Belt and the 21st-Century Maritime Silk Road" during long time, the group established a **chain service system** offering **international resources, customer-oriented services, multi-category products, professional training and e-commerce services**.

Merit Link business model's core is the complete service system based on 5 pillars: warehouse, logistic and after-sales services, product training, promotion and marketing activities, talent development and e-commerce platform.

Merit Link Brands portfolio offer **in house Brands, agent Brands** and **famous Brands**. In house portfolio includes well-known brands such as **Crown, DWT, Tosan and Mytol**.

Through long-time partnering with distributors in overseas markets, the group obtained strong influence in the markets such as **China and South-east Asia, Middle-East and Africa, C.I.S. and Middle Europe**.

Merit Link boosts its mission as **"Meet the consumer`s needs with best products and services by integrating resources across the industrial chains"**. With all of our brands, businesses, and people working in unison, we can create scale advantages by allocating resources more strategically and efficiently.



OUR MISSION

A MANUFACTURER'S EXPERIENCE,
THE STRENGTH OF OUR BRAND, OUR NUMBERS.

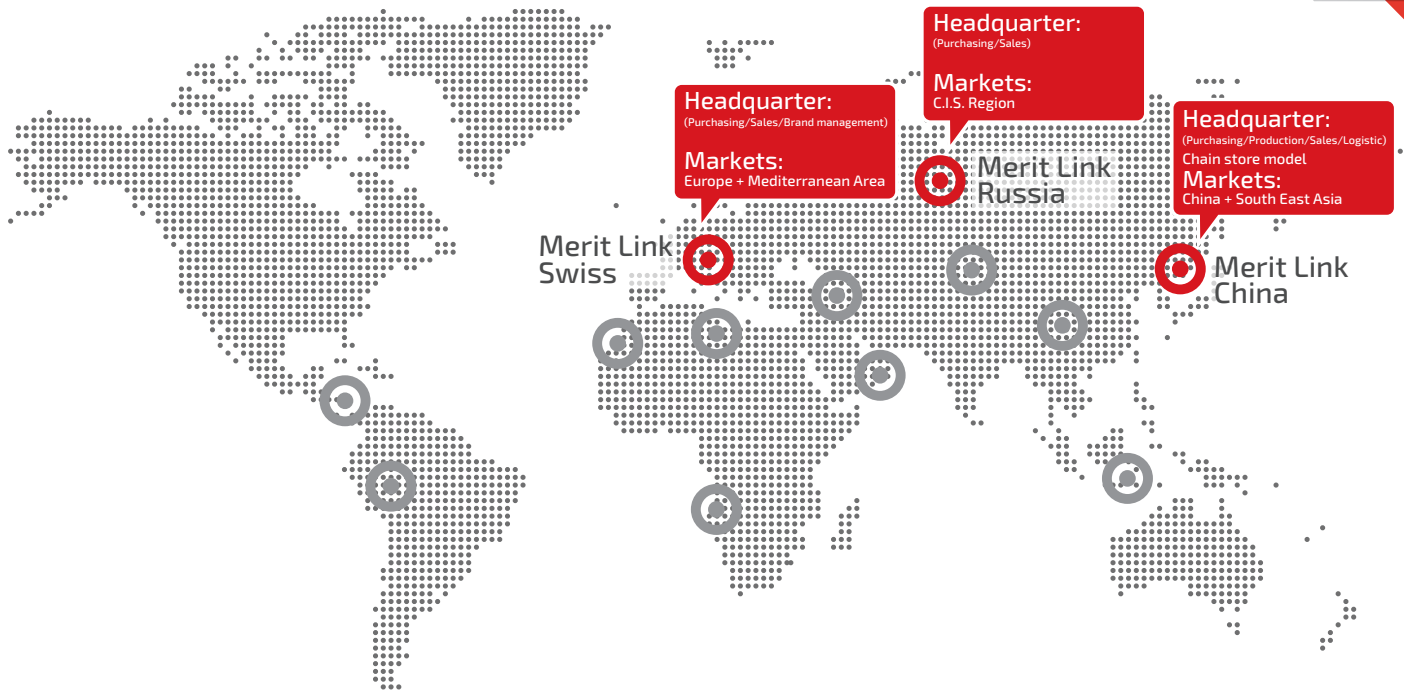

4 FACTORIES

We have been designing and developing high-performance power tools since 1980. Our engineers are constantly developing our product range to always offer the best tools for every application. In our 4 plants we manufacture according to the most current international standards pursuing continuous improvement in performance, balance, versatility and longevity of our power tools.

+1.500 EMPLOYEES

CROWN is a global company with over 1,500 employees worldwide who work every day to develop and improve our international business. All departments and professionals involved, work with the specific goal of making the best products and services that ensure professionals can work in the most productive way.

105.000 m²

Our production facilities are spread over more than 105,000 square meters allowing us to manage the entire production system effectively, from component storage, to production, to finished product storage.

10 MILLIONS OF PRODUCTS

CROWN produces 10 million power tools annually. Our assortment is produced following strict quality controls throughout the supply chain. From supply control to production management through TPS logics.

50+ NATIONS

CROWN is present in more than 50 countries worldwide and our market share is growing rapidly year after year. We develop our markets directly through directly controlled companies thus shortening the distribution chain and always ensuring the best service and support to our customers.

CROWN ONLINE

ALL INFORMATION JUST A CLICK AWAY.

WWW.CROWN-TOOLS-EU.COM



The CROWN website is an online showcase for our products but also a working tool for those in the industry. In addition to being able to view all the technical features and commercial details of our products, it is possible to download catalogs and promotional flyers, access the service section where instruction manuals can be consulted, and the restricted area where various multimedia content for marketing needs can be downloaded.

News

Stay up-to-date about CROWN news by browsing our home page.

Technical specifications

On the CROWN website you can find all the details about the technical performance and main functions of our products.

Catalogs and fliers

View online and download the latest version of the product catalog and promotional flyers.

Usage applications

With the compare function you can compare the performance of our products and choose the one best suited to your needs.

Documentation

Download the user manual and exploded view drawing directly from the service section or on the product page:

www.crown-tools-service.com

Reserved area

A dedicated area for distributors where they can download all sales support communication materials.

YouTube channel

Visit our youtube channel and subscribe to view in-depth videos on our product range.

YouTube

Subscribe to our channel



CONTENTS

POWER TOOLS: BATTERY RANGE

7

Battery tools
3,6V e 12V

10

Fastening, drilling
and hammering
20V Max

16

Metal working
20V Max

17

Wood working
20V Max

19

Various tools
20V Max

20

Outdoor tools
20V Max

22

Batteries and
chargers
20V Max

24

Cases and bags
20V Max

POWER TOOLS: CORDED RANGE

26

Fastening
and drilling

29

Hammers
and breakers

34

Metal working

40

Cutting
and sawing

44

Wood working

47

Various tools

50

Laser and digital
measuring
tools

52

Outdoor tools

53

Welding machines
and compressors

ACCESSORIES

55

Cutting, grinding
and diamond discs

56

Sabre saw blades

56

Sanding papers
and base plates

57

Blades for circular
and plunge saws

58

Carbon brushes

CORDLESS SCREWDRIVER

CT22053 TB

- 1/4" HEXAGONAL TOOL HOLDER
- VARIABLE TORQUE
- REVERSE FUNCTION
- SOFT GRIP
- USB-C CHARGING SOCKET

ACCESSORIES INCLUDED

USB cable, Magnetic holder, Bits: (25 mm) SL3, SL4, SL5, SL6 | (45 mm) SL3, SL5 | (25 mm) PZ1, PZ2, PZ3 | (25 mm) T10, T15, T20, T25, T30 | (45 mm) T20 | (25 mm) PH1, PH2, PH3 | (45 mm) PH1, PH2 | (25 mm) H2, H3, H4, H5, H6.



4 V

NEW

BATTERY CAPACITY	2 AH
BATTERY CHARGING TIME	60 MIN
NO-LOAD SPEED	260 MIN ⁻¹

TURNDOWN OF ROTATION TORQUE	5 NM
NUMBER OF STAGES OF ROTATION TORQUE	3
WEIGHT	0,28 KG

CORDLESS SCREWDRIVER

CT22024 MC

- SPINDLE AUTOMATIC LOCKING
- 1/4" HEXAGONAL TOOL HOLDER
- VARIABLE TORQUE
- 2 MODES (SCREWDRIVING / DRILLING)
- REVERSE FUNCTION
- INTEGRATED LED LIGHT
- SOFT GRIP

ACCESSORIES INCLUDED

Bits: SL2,5, 3, 4, 5, 6 mm, PH0, PH1, PH2, PH3, PH4, PZ0, PZ1, PZ2, PZ3, PZ4, H2, 3, 4, 5, 6 mm, T5, T6, T8, T10 (x2), T15 (x2), T20 (x2), T25, Extension 50 mm. Charger, Belt clip.



3,6 V

BATTERY CAPACITY	1,5 AH
BATTERY CHARGING TIME	3,5 H
NO-LOAD SPEED	200 MIN ⁻¹
CHUCK TIGHTENING RANGE	6,35 MM
MAX. TORQUE	3,5 NM
MAX. SCREW DIAMETER	4 MM
WEIGHT	0,45 KG

CORDLESS SCREWDRIVER

CT21072HBX-2 BMC

- SPINDLE AUTOMATIC LOCKING
- 1/4" HEXAGONAL TOOL HOLDER
- STEP SPEED SELECTION
- ELECTRONIC SPEED ADJUSTMENT
- VARIABLE TORQUE
- REVERSE FUNCTION
- QUICK CHARGE

ACCESSORIES INCLUDED

Batteries 2 pcs, Charger, Belt clip.



12 V

BATTERY CAPACITY	2 AH
BATTERY CHARGING TIME	60 MIN
NO-LOAD SPEED (GEAR I / II)	0-380 / 0-1250 MIN ⁻¹
TOOL HOLDER	1/4" HEXAGONAL
MAX. TORQUE (SOFT / HARD)	19 / 30 NM
MAX. SCREW DIAMETER	6 MM
WEIGHT	0,85 KG

CORDLESS DRILL AND SCREWDRIVER

CT21072HX-2 BMC

- SPINDLE AUTOMATIC LOCKING
- KEYLESS CHUCK
- STEP SPEED SELECTION
- ELECTRONIC SPEED ADJUSTMENT
- VARIABLE TORQUE
- 2 MODES (SCREWDRIVING / DRILLING)
- QUICK CHARGE

ACCESSORIES INCLUDED

Batteries 2 pcs, Charger, Belt clip.



12 V

BATTERY CAPACITY	2 AH
BATTERY CHARGING TIME	60 MIN
NO-LOAD SPEED (GEAR I / II)	0-380 / 0-1250 MIN ⁻¹
CHUCK TIGHTENING RANGE	0,8-10 MM
MAX. TORQUE (SOFT / HARD)	19 / 30 NM
DRILLING OUTPUT IN STEEL	10 MM
DRILLING OUTPUT IN WOOD	28 MM
MAX. SCREW DIAMETER	6 MM
WEIGHT	0,96 KG

CORDLESS DRILL AND SCREWDRIVER

CT21081HQ-2 BMC

- SPINDLE AUTOMATIC LOCKING
- QUICK-CHANGE ATTACHMENTS
- STEP SPEED SELECTION
- ELECTRONIC SPEED ADJUSTMENT
- VARIABLE TORQUE
- 2 MODES (SCREWDRIVING / DRILLING)
- QUICK CHARGE

ACCESSORIES INCLUDED

Batteries 2 pcs, Charger, Quick-change keyless chuck, Quick-change tool holder, Quick-change angle tool holder, Belt clip.



12 V

BATTERY CAPACITY	2 AH
BATTERY CHARGING TIME	60 MIN
NO-LOAD SPEED (GEAR I / II)	0-380 / 0-1250 MIN ⁻¹
CHUCK TIGHTENING RANGE	0,8-10 MM
MAX. TORQUE (SOFT / HARD)	19 / 30 NM
DRILLING OUTPUT IN STEEL	10 MM
DRILLING OUTPUT IN WOOD	28 MM
MAX. SCREW DIAMETER	6 MM
WEIGHT	1,13 KG

20 V MAX PLATFORM



HIGH PERFORMANCE BRUSHLESS MOTOR

THE 20 V MAX RANGE INCLUDES NEW TOOLS WITH BRUSHLESS MOTOR WITH ADVANCED TECHNOLOGY THAT GUARANTEES GREATER PERFORMANCE, LONGER LIFE, LIGHTER AND MORE COMPACT TOOLS.

BRUSHLESS

A WIDE RANGE OF CORDLESS PRODUCTS

A CONSTANTLY GROWING RANGE OF OVER 50 MODELS, DESIGNED TO FIT THE MOST DEMANDING APPLICATIONS.

+50 MODELS

THE 4 LEVELS OF ADAPTABILITY ALLOW TO CHOOSE THE TYPE OF BATTERY AND THE DURATION OF USE.

2AH, 4AH, 5AH, 8AH

OUR QUICK CHARGERS ALLOW TO BE ALWAYS OPERATIONAL AND OPTIMIZE YOUR WORK.

2A, 4A, 9A

21700 OPTIMIZED CELLS

THE NEW 21700 PROFESSIONAL LITHIUM BATTERY CELLS HAVE A LOWER IMPEDANCE WHICH GUARANTEES MORE POWER. OUR 20 V MAX BATTERIES HAVE SLOW SELF-DISCHARGE WHICH GUARANTEES LONGER LIFE. THE 20 V MAX BATTERIES HAVE A REDUCED MEMORY EFFECT WHICH GUARANTEES LONGER LIFE CYCLES.

+35%*
CAPACITY

-10%*
WEIGHT

LONG
DURATION

REDUCED
MEMORY EFFECT

*21700 VS 18650 CELL BATTERIES COMPARATIVE.



Angle grinder
CT23008-125HX
BRUSHLESS





SCAN THE QR CODE

to watch the promo video on YouTube.

Drill and screwdriver
CT21128HMX
BRUSHLESS

Impact drill and screwdriver
CT21127HMX
BRUSHLESS

Impact drill and screwdriver
CT21112HMX
BRUSHLESS

Impact drill and screwdriver
CT21075HMX

Impact drill and screwdriver
CT21093HMX
BRUSHLESS

Impact screwdriver
CT22051HX
BRUSHLESS

Hedge trimmer
CT29015HX

Lawn mower
CT29018HX
BRUSHLESS

Chainsaw
CT29006HX
BRUSHLESS

Brush cutter
CT29012HX

Blower
CT29013HX

Impact wrench
CT22057HX
BRUSHLESS

Impact wrench
CT22050HX
BRUSHLESS

Impact wrench
CT22058HX
BRUSHLESS

Mixer
CT26012HX
BRUSHLESS

High-pressure washer
CT63002HX

Power planer
CT24001HX

Rotary sander
CT23011HX

Orbital sander
CT23010HX

Brad nailer
CT61001HX

Sprayer
CT29003HX

Blower
CT29002HX

Edge trimmer
CT26010HX
BRUSHLESS

Torch
CT26018HX

Torch
CT26008HX

Shears
CT29001HX
BRUSHLESS

Vacuum cleaner
CT63001HX

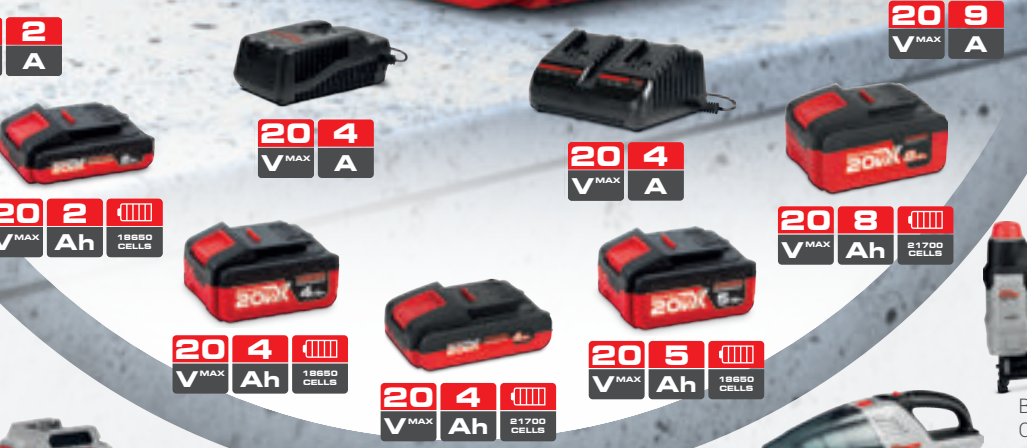

2 A

20 9 V MAX A

20 4 V MAX A

20 4 V MAX A

20 8 V MAX Ah 1860 CELLS

20 2 V MAX Ah 1860 CELLS

20 4 V MAX Ah 1860 CELLS

20 5 V MAX Ah 1860 CELLS

20 4 V MAX Ah 1860 CELLS

20 4 V MAX Ah 1860 CELLS

20 5 V MAX Ah 1860 CELLS

CORDLESS DRILL AND SCREWDRIVER
CT21128HMX

- METAL KEYLESS CHUCK
- SPINDLE AUTOMATIC LOCKING
- ROTATIONAL DIRECTION SWITCH
- ELECTRONIC SPEED ADJUSTMENT
- VARIABLE TORQUE
- 2 MODES (SCREWDRIVING / DRILLING)

ACCESSORI INCLUSI
Belt clip, PH2-6 (50mm) bit.



20VX
NEW

BRUSHLESS

BATTERY COMPATIBILITY	2 AH, 4 AH, 5 AH, 8 AH
NO-LOAD SPEED (GEAR I / II)	0-500 / 0-1800 MIN ⁻¹
CHUCK TIGHTENING RANGE	0,8-10 MM
MAX. TORQUE (SOFT / HARD)	27 / 50 NM
DRILLING OUTPUT IN STEEL	13 MM
DRILLING OUTPUT IN WOOD	32 MM
MAX. SCREW DIAMETER	10 MM
WEIGHT	0,91 KG

CORDLESS DRILL AND SCREWDRIVER
CT21128HMX IMC

- METAL KEYLESS CHUCK
- SPINDLE AUTOMATIC LOCKING
- ROTATIONAL DIRECTION SWITCH
- ELECTRONIC SPEED ADJUSTMENT
- VARIABLE TORQUE
- 2 MODES (SCREWDRIVING / DRILLING)

ACCESSORIES INCLUDED
Belt clip, PH2-6 (50mm) bit.



20VX
NEW

BRUSHLESS

BATTERY COMPATIBILITY	2 AH, 4 AH, 5 AH, 8 AH
NO-LOAD SPEED (GEAR I / II)	0-500 / 0-1800 MIN ⁻¹
CHUCK TIGHTENING RANGE	0,8-10 MM
MAX. TORQUE (SOFT / HARD)	27 / 50 NM
DRILLING OUTPUT IN STEEL	13 MM
DRILLING OUTPUT IN WOOD	32 MM
MAX. SCREW DIAMETER	10 MM
WEIGHT	0,91 KG

CORDLESS DRILL AND SCREWDRIVER
CT21128HMX-2 IMC

- METAL KEYLESS CHUCK
- SPINDLE AUTOMATIC LOCKING
- ROTATIONAL DIRECTION SWITCH
- ELECTRONIC SPEED ADJUSTMENT
- VARIABLE TORQUE
- 2 MODES (SCREWDRIVING / DRILLING)

ACCESSORIES INCLUDED
Batteries 2pcs, Charger,
Belt clip, PH2-6 (50mm) bit.



20VX
NEW

BRUSHLESS

BATTERY CAPACITY	2 AH
NO-LOAD SPEED (GEAR I / II)	0-500 / 0-1800 MIN ⁻¹
CHUCK TIGHTENING RANGE	0,8-10 MM
MAX. TORQUE (SOFT / HARD)	27 / 50 NM
DRILLING OUTPUT IN STEEL	13 MM
DRILLING OUTPUT IN WOOD	32 MM
MAX. SCREW DIAMETER	10 MM
WEIGHT	1,28 KG

CORDLESS IMPACT DRILL AND SCREWDRIVER
CT21075HMX-2 BMC

- STEP SPEED SELECTION
- SPINDLE AUTOMATIC LOCKING
- METAL KEYLESS CHUCK
- STEP SPEED SELECTION
- ELECTRONIC SPEED ADJUSTMENT
- VARIABLE TORQUE
- 3 MODES (SCREWDRIVING / DRILLING / IMPACT DRILLING)

ACCESSORIES INCLUDED
Additional handle, Depth stop, Belt clip, Batteries 2 pcs, Charger.



20VX

BATTERY CAPACITY	2 AH
NO-LOAD SPEED (GEAR I / II)	0-400 / 0-1500 MIN ⁻¹
IMPACT RATE (GEAR I / II)	0-6000 / 0-22500 MIN ⁻¹
MAX. TORQUE (SOFT / HARD)	45 / 55 NM
CHUCK TIGHTENING RANGE	1,5-13 MM
DRILLING OUTPUT IN CONCRETE	16 MM
DRILLING OUTPUT IN STEEL	13 MM
DRILLING OUTPUT IN WOOD	40 MM
WEIGHT	1,62 KG



CORDLESS IMPACT DRILL AND SCREWDRIVER
CT21075HMX-4 BMC

- STEP SPEED SELECTION
- SPINDLE AUTOMATIC LOCKING
- METAL KEYLESS CHUCK
- STEP SPEED SELECTION
- ELECTRONIC SPEED ADJUSTMENT
- VARIABLE TORQUE
- 3 MODES (SCREWDRIVING / DRILLING / IMPACT DRILLING)

ACCESSORIES INCLUDED
Additional handle, Depth stop, Belt clip, Batteries 2 pcs, Charger.



20VX

BATTERY CAPACITY	4 AH
NO-LOAD SPEED (GEAR I / II)	0-400 / 0-1500 MIN ⁻¹
IMPACT RATE (GEAR I / II)	0-6000 / 0-22500 MIN ⁻¹
MAX. TORQUE (SOFT / HARD)	45 / 55 NM
CHUCK TIGHTENING RANGE	1,5-13 MM
DRILLING OUTPUT IN CONCRETE	16 MM
DRILLING OUTPUT IN STEEL	13 MM
DRILLING OUTPUT IN WOOD	40 MM
WEIGHT	1,88 KG

CORDLESS IMPACT DRILL AND SCREWDRIVER

CT21093HMX

- BRUSHLESS MOTOR
- STEP SPEED SELECTION
- REVERSE FUNCTION
- METAL KEYLESS CHUCK
- ELECTRONIC SPEED ADJUSTMENT
- VARIABLE TORQUE
- 3 MODES (SCREWDRIVING / DRILLING / IMPACT DRILLING)

ACCESSORIES INCLUDED

Additional handle, Depth stop, Belt clip.



20VX

BRUSHLESS

COMPATIBLES BATTERIES	2 AH, 4 AH, 5 AH, 8 AH
NO-LOAD SPEED (GEAR I / II)	0-500 / 0-2000 MIN ⁻¹
IMPACT RATE (GEAR I / II)	0-7500 / 0-30000 MIN ⁻¹
CHUCK TIGHTENING RANGE	1,5-13 MM
MAX. TORQUE (SOFT/HARD)	50 / 75 NM
DRILLING OUTPUT IN CONCRETE	16 MM
DRILLING OUTPUT IN STEEL	13 MM
DRILLING OUTPUT IN WOOD	40 MM
WEIGHT	1,39 KG

CORDLESS IMPACT DRILL AND SCREWDRIVER

CT21093HMX-4 BMC

- BRUSHLESS MOTOR
- STEP SPEED SELECTION
- REVERSE FUNCTION
- METAL KEYLESS CHUCK
- ELECTRONIC SPEED ADJUSTMENT
- VARIABLE TORQUE
- 3 MODES (SCREWDRIVING / DRILLING / IMPACT DRILLING)

ACCESSORIES INCLUDED

Batteries 2 pcs, Charger, Additional handle, Depth stop, Belt clip, Screwdriver bit (double head).



20VX

BRUSHLESS

BATTERY CAPACITY	4 AH
NO-LOAD SPEED (GEAR I / II)	0-500 / 0-2000 MIN ⁻¹
IMPACT RATE (GEAR I / II)	0-7500 / 0-30000 MIN ⁻¹
CHUCK TIGHTENING RANGE	1,5-13 MM
MAX. TORQUE (SOFT/HARD)	50 / 75 NM
DRILLING OUTPUT IN CONCRETE	16 MM
DRILLING OUTPUT IN STEEL	13 MM
DRILLING OUTPUT IN WOOD	40 MM
WEIGHT	2,05 KG

CORDLESS IMPACT DRILL AND SCREWDRIVER

CT21127HMX

- BRUSHLESS MOTOR
- STEP SPEED SELECTION
- REVERSE FUNCTION
- 3 MODES (SCREWDRIVING / DRILLING / IMPACT DRILLING)
- METAL KEYLESS CHUCK
- ELECTRONIC SPEED ADJUSTMENT
- VARIABLE TORQUE

ACCESSORIES INCLUDED

Belt clip, PH2-6 (50mm) bit, Additional handle.



20VX

NEW

BRUSHLESS

COMPATIBLES BATTERIES	2 AH, 4 AH, 5 AH, 8 AH
NO-LOAD SPEED (GEAR I / II)	0-500/0-2100 MIN ⁻¹
IMPACT RATE (GEAR I / II)	0-7500/0-32000 MIN ⁻¹
CHUCK TIGHTENING RANGE	1,5-13 MM
MAX. TORQUE (SOFT/HARD)	50 / 100 NM
DRILLING OUTPUT IN CONCRETE	12 MM
DRILLING OUTPUT IN STEEL	13 MM
DRILLING OUTPUT IN WOOD	38 MM
WEIGHT	1,49 KG

CORDLESS IMPACT DRILL AND SCREWDRIVER

CT21127HMX-5 IMC

- BRUSHLESS MOTOR
- STEP SPEED SELECTION
- REVERSE FUNCTION
- 3 MODES (SCREWDRIVING / DRILLING / IMPACT DRILLING)
- METAL KEYLESS CHUCK
- ELECTRONIC SPEED ADJUSTMENT
- VARIABLE TORQUE

ACCESSORIES INCLUDED

Batteries 2pcs, Charger, Belt clip, PH2-6 (50mm) bit, Additional handle.



20VX

NEW

BRUSHLESS

BATTERY CAPACITY	5 AH
NO-LOAD SPEED (GEAR I / II)	0-500/0-2100 MIN ⁻¹
IMPACT RATE (GEAR I / II)	0-7500/0-32000 MIN ⁻¹
CHUCK TIGHTENING RANGE	1,5-13 MM
MAX. TORQUE (SOFT/HARD)	50 / 100 NM
DRILLING OUTPUT IN CONCRETE	12 MM
DRILLING OUTPUT IN STEEL	13 MM
DRILLING OUTPUT IN WOOD	38 MM
WEIGHT	2,18 KG

CORDLESS IMPACT DRILL AND SCREWDRIVER

CT21127HMX IMC

- BRUSHLESS MOTOR
- STEP SPEED SELECTION
- REVERSE FUNCTION
- 3 MODES (SCREWDRIVING / DRILLING / IMPACT DRILLING)
- METAL KEYLESS CHUCK
- ELECTRONIC SPEED ADJUSTMENT
- VARIABLE TORQUE

ACCESSORIES INCLUDED

Belt clip, PH2-6 (50mm) bit, Additional handle.



20VX

NEW

BRUSHLESS

COMPATIBLES BATTERIES	2 AH, 4 AH, 5 AH, 8 AH
NO-LOAD SPEED (GEAR I / II)	0-500/0-2100 MIN ⁻¹
IMPACT RATE (GEAR I / II)	0-7500/0-32000 MIN ⁻¹
CHUCK TIGHTENING RANGE	1,5-13 MM
MAX. TORQUE (SOFT/HARD)	50 / 100 NM
DRILLING OUTPUT IN CONCRETE	12 MM
DRILLING OUTPUT IN STEEL	13 MM
DRILLING OUTPUT IN WOOD	38 MM
WEIGHT	1,49 KG

CORDLESS IMPACT DRILL AND SCREWDRIVER

CT21112HMX

- BRUSHLESS MOTOR
- STEP SPEED SELECTION
- REVERSE FUNCTION
- METAL KEYLESS CHUCK
- 3 MODES (SCREWDRIVING / DRILLING / IMPACT DRILLING)
- ELECTRONIC SPEED ADJUSTMENT
- VARIABLE TORQUE

ACCESSORIES INCLUDED
Belt clip, PH2-6 (50mm) bit,
Additional handle.

BRUSHLESS

COMPATIBLES BATTERIES	2 AH, 4 AH, 5 AH, 8 AH
NO-LOAD SPEED (GEAR I / II)	0-500/0-2000 MIN ⁻¹
IMPACT RATE (GEAR I / II)	0-7500/0-32000 MIN ⁻¹
CHUCK TIGHTENING RANGE	1,5-13 MM
MAX. TORQUE (SOFT/HARD)	60 / 120 NM
DRILLING OUTPUT IN CONCRETE	13 MM
DRILLING OUTPUT IN STEEL	13 MM
DRILLING OUTPUT IN WOOD	38 MM
WEIGHT	1,59 KG



20VX

NEW

CORDLESS IMPACT DRILL AND SCREWDRIVER

CT21112HMX-5 IMC

- BRUSHLESS MOTOR
- STEP SPEED SELECTION
- REVERSE FUNCTION
- METAL KEYLESS CHUCK
- 3 MODES (SCREWDRIVING / DRILLING / IMPACT DRILLING)
- ELECTRONIC SPEED ADJUSTMENT
- VARIABLE TORQUE

ACCESSORIES INCLUDED
Batteries 2pcs, Charger,
Belt clip, PH2-6 (50mm) bit,
Additional handle.

BRUSHLESS



20VX

NEW

CORDLESS IMPACT DRILL AND SCREWDRIVER

CT21112HMX IMC

- BRUSHLESS MOTOR
- STEP SPEED SELECTION
- REVERSE FUNCTION
- METAL KEYLESS CHUCK
- 3 MODES (SCREWDRIVING / DRILLING / IMPACT DRILLING)
- ELECTRONIC SPEED ADJUSTMENT
- VARIABLE TORQUE

ACCESSORIES INCLUDED
Belt clip, PH2-6 (50mm) bit,
Additional handle.

BRUSHLESS

COMPATIBLES BATTERIES	2 AH, 4 AH, 5 AH, 8 AH
NO-LOAD SPEED (GEAR I / II)	0-500/0-2000 MIN ⁻¹
IMPACT RATE (GEAR I / II)	0-7500/0-32000 MIN ⁻¹
CHUCK TIGHTENING RANGE	1,5-13 MM
MAX. TORQUE (SOFT/HARD)	60 / 120 NM
DRILLING OUTPUT IN CONCRETE	13 MM
DRILLING OUTPUT IN STEEL	13 MM
DRILLING OUTPUT IN WOOD	38 MM
WEIGHT	1,59 KG



20VX

NEW

BRUSHLESS

BATTERY CAPACITY	5 AH
NO-LOAD SPEED (GEAR I / II)	0-500/0-2000 MIN ⁻¹
IMPACT RATE (GEAR I / II)	0-7500/0-32000 MIN ⁻¹
CHUCK TIGHTENING RANGE	1,5-13 MM
MAX. TORQUE (SOFT/HARD)	60 / 120 NM
DRILLING OUTPUT IN CONCRETE	13 MM
DRILLING OUTPUT IN STEEL	13 MM
DRILLING OUTPUT IN WOOD	38 MM
WEIGHT	2,28 KG

CORDLESS IMPACT SCREWDRIVER

CT22051HX

- BRUSHLESS MOTOR
- 1/4" HEX TOOL HOLDER
- ELECTRONIC SPEED ADJUSTMENT
- VARIABLE TORQUE
- REVERSE FUNCTION
- INTEGRATED LED LIGHT
- SOFT GRIP

ACCESSORIES INCLUDED
Belt clip

BRUSHLESS

COMPATIBLES BATTERIES	2 AH, 4 AH, 5 AH, 8 AH
NO-LOAD SPEED (GEAR I / II / III)	0-1500 / 0-2000 / 0-2500 MIN ⁻¹
IMPACT RATE (GEAR I / II / III)	0-1800 / 0-2700 / 0-3300 MIN ⁻¹
TOOL HOLDER	1/4" HEX
MAX. TORQUE	280 NM
MAX. BOLT / NUT DIAMETER	M22
WEIGHT	1,23 KG



20VX

NEW

CORDLESS IMPACT SCREWDRIVER

CT22051HX IMC

- BRUSHLESS MOTOR
- 1/4" HEX TOOL HOLDER
- ELECTRONIC SPEED ADJUSTMENT
- VARIABLE TORQUE
- REVERSE FUNCTION
- INTEGRATED LED LIGHT
- SOFT GRIP

ACCESSORIES INCLUDED
Belt clip

BRUSHLESS

COMPATIBLES BATTERIES	2 AH, 4 AH, 5 AH, 8 AH
NO-LOAD SPEED (GEAR I / II / III)	0-1500 / 0-2000 / 0-2500 MIN ⁻¹
IMPACT RATE (GEAR I / II / III)	0-1800 / 0-2700 / 0-3300 MIN ⁻¹
TOOL HOLDER	1/4" HEX
MAX. TORQUE	280 NM
MAX. BOLT / NUT DIAMETER	M22
WEIGHT	1,23 KG



20VX

NEW

CORDLESS IMPACT SCREWDRIVER
CT22051HX-5 IMC

- BRUSHLESS MOTOR
- 1/4" HEX TOOL HOLDER
- ELECTRONIC SPEED ADJUSTMENT
- VARIABLE TORQUE
- REVERSE FUNCTION
- INTEGRATED LED LIGHT
- SOFT GRIP

ACCESSORIES INCLUDED
Batteries 2pcs, Charger,
Belt clip.



20VX
NEW

280NM
TORQUE

BRUSHLESS

BATTERY CAPACITY	5 AH
NO-LOAD SPEED (GEAR I / II / III)	0-1500 / 0-2000 / 0-2500 MIN ⁻¹
IMPACT RATE (GEAR I / II / III)	0-1800 / 0-2700 / 0-3300 MIN ⁻¹
TOOL HOLDER	1/4" HEX
MAX. TORQUE	280 NM
MAX. BOLT / NUT DIAMETER	M22
WEIGHT	1,92 KG

CORDLESS IMPACT WRENCH
CT22050HX

- BRUSHLESS MOTOR
- 1/2" SQUARE TOOL HOLDER
- ELECTRONIC SPEED ADJUSTMENT
- VARIABLE TORQUE
- REVERSE FUNCTION
- INTEGRATED LED LIGHT
- SOFT GRIP

ACCESSORIES INCLUDED
Pin and spring, Belt clip.



20VX
NEW

280NM
TORQUE

BRUSHLESS

COMPATIBLES BATTERIES	2 AH, 4 AH, 5 AH, 8 AH
NO-LOAD SPEED (GEAR I / II / III)	0-1500 / 0-1900 / 0-2300 MIN ⁻¹
IMPACT RATE (GEAR I / II / III)	0-1800 / 0-2500 / 0-3100 MIN ⁻¹
TOOL HOLDER	1/2" SQUARE
MAX. TORQUE	350 NM
MAX. BOLT / NUT DIAMETER	M22
WEIGHT	1,23 KG

CORDLESS IMPACT WRENCH
CT22050HX-5 IMC

- BRUSHLESS MOTOR
- 1/2" SQUARE TOOL HOLDER
- ELECTRONIC SPEED ADJUSTMENT
- VARIABLE TORQUE
- REVERSE FUNCTION
- INTEGRATED LED LIGHT
- SOFT GRIP

ACCESSORIES INCLUDED
Batteries 2pcs, Charger,
Pin and spring, Belt clip.



20VX
NEW

350NM
TORQUE

BRUSHLESS

BATTERY CAPACITY	5 AH
NO-LOAD SPEED (GEAR I / II / III)	0-1500 / 0-1900 / 0-2300 MIN ⁻¹
IMPACT RATE (GEAR I / II / III)	0-1800 / 0-2500 / 0-3100 MIN ⁻¹
TOOL HOLDER	1/2" SQUARE
MAX. TORQUE	350 NM
MAX. BOLT / NUT DIAMETER	M22
WEIGHT	1,92 KG

CORDLESS IMPACT WRENCH
CT22050HX IMC

- BRUSHLESS MOTOR
- 1/2" SQUARE TOOL HOLDER
- ELECTRONIC SPEED ADJUSTMENT
- VARIABLE TORQUE
- REVERSE FUNCTION
- INTEGRATED LED LIGHT
- SOFT GRIP

ACCESSORIES INCLUDED
Pin and spring, Belt clip.



20VX
NEW

350NM
TORQUE

BRUSHLESS

COMPATIBLES BATTERIES	2 AH, 4 AH, 5 AH, 8 AH
NO-LOAD SPEED (GEAR I / II / III)	0-1500 / 0-1900 / 0-2300 MIN ⁻¹
IMPACT RATE (GEAR I / II / III)	0-1800 / 0-2500 / 0-3100 MIN ⁻¹
TOOL HOLDER	1/2" SQUARE
MAX. TORQUE	350 NM
MAX. BOLT / NUT DIAMETER	M22
WEIGHT	1,23 KG

CORDLESS IMPACT WRENCH
CT22057HX

- BRUSHLESS MOTOR
- 1/2" SQUARE TOOL HOLDER
- ELECTRONIC SPEED ADJUSTMENT
- VARIABLE TORQUE
- REVERSE FUNCTION
- INTEGRATED LED LIGHT
- SOFT GRIP

ACCESSORIES INCLUDED
Belt clip.



20VX
NEW

600NM
TORQUE

BRUSHLESS

COMPATIBLES BATTERIES	2 AH, 4 AH, 5 AH, 8 AH
NO-LOAD SPEED (GEAR I / II / III)	0-1200 / 0-1500 / 0-1900 MIN ⁻¹
IMPACT RATE (GEAR I / II / III)	0-1700 / 2100 / 2400 MIN ⁻¹
TOOL HOLDER	1/2" SQUARE
MAX. TORQUE (SCREW / UNSCREW)	400 - 550 - 600 / 900 NM
MAX. BOLT / NUT DIAMETER	M28
WEIGHT	1,8 KG

CORDLESS IMPACT WRENCH
CT22057HX IMC

- BRUSHLESS MOTOR
- 1/2" SQUARE TOOL HOLDER
- ELECTRONIC SPEED ADJUSTMENT
- VARIABLE TORQUE
- REVERSE FUNCTION
- INTEGRATED LED LIGHT
- SOFT GRIP

ACCESSORIES INCLUDED
Belt clip.



20VX
NEW

BRUSHLESS

COMPATIBLES BATTERIES	2 AH, 4 AH, 5 AH, 8 AH
NO-LOAD SPEED (GEAR I / II / III)	0-1200 / 0-1500 / 0-1900 MIN ⁻¹
IMPACT RATE (GEAR I / II / III)	0-1700 / 2100 / 2400 MIN ⁻¹
TOOL HOLDER	1/2" SQUARE
MAX. TORQUE (SCREW / UNSCREW)	400 - 550 - 600 / 900 NM
MAX. BOLT / NUT DIAMETER	M28
WEIGHT	1,8 KG

CORDLESS IMPACT WRENCH
CT22057HX-5 IMC

- BRUSHLESS MOTOR
- 1/2" SQUARE TOOL HOLDER
- ELECTRONIC SPEED ADJUSTMENT
- VARIABLE TORQUE
- REVERSE FUNCTION
- INTEGRATED LED LIGHT
- SOFT GRIP

ACCESSORIES INCLUDED
Batteries 2pcs, Charger,
Belt clip.



20VX
NEW

BRUSHLESS

BATTERY CAPACITY	5 AH
NO-LOAD SPEED (GEAR I / II / III)	0-1200 / 0-1500 / 0-1900 MIN ⁻¹
IMPACT RATE (GEAR I / II / III)	0-1700 / 2100 / 2400 MIN ⁻¹
TOOL HOLDER	1/2" SQUARE
MAX. TORQUE (SCREW / UNSCREW)	500 - 550 - 600 / 1000 NM
MAX. BOLT / NUT DIAMETER	M28
WEIGHT	2,49 KG

CORDLESS IMPACT WRENCH
CT22058HX

- BRUSHLESS MOTOR
- 3/4" SQUARE TOOL HOLDER
- ELECTRONIC SPEED ADJUSTMENT
- VARIABLE TORQUE
- REVERSE FUNCTION
- INTEGRATED LED LIGHT
- SOFT GRIP



20VX
NEW

BRUSHLESS

COMPATIBLES BATTERIES	2 AH, 4 AH, 5 AH, 8 AH
NO-LOAD SPEED (GEAR I / II / III)	0-900 / 0-1200 / 0-1500 MIN ⁻¹
IMPACT RATE (GEAR I / II / III)	0-1800 / 2200 / 2800 MIN ⁻¹
TOOL HOLDER	3/4" SQUARE
MAX. TORQUE (SCREW / UNSCREW)	600 - 800 - 1000 / 1600 NM
MAX. BOLT / NUT DIAMETER	M30
WEIGHT	3 KG

CORDLESS IMPACT WRENCH
CT22058HX IMC

- BRUSHLESS MOTOR
- 3/4" SQUARE TOOL HOLDER
- ELECTRONIC SPEED ADJUSTMENT
- VARIABLE TORQUE
- REVERSE FUNCTION
- INTEGRATED LED LIGHT
- SOFT GRIP



20VX
NEW

BRUSHLESS

BATTERY CAPACITY	5 AH
NO-LOAD SPEED (GEAR I / II / III)	0-900 / 0-1200 / 0-1500 MIN ⁻¹
IMPACT RATE (GEAR I / II / III)	0-1800 / 2200 / 2800 MIN ⁻¹
TOOL HOLDER	3/4" SQUARE
MAX. TORQUE (SCREW / UNSCREW)	600 - 800 - 1000 / 1600 NM
MAX. BOLT / NUT DIAMETER	M30
WEIGHT	3,69 KG

CORDLESS IMPACT WRENCH
CT22058HX IMC

- BRUSHLESS MOTOR
- 3/4" SQUARE TOOL HOLDER
- ELECTRONIC SPEED ADJUSTMENT
- VARIABLE TORQUE
- REVERSE FUNCTION
- INTEGRATED LED LIGHT
- SOFT GRIP



20VX
NEW

BRUSHLESS

COMPATIBLES BATTERIES	2 AH, 4 AH, 5 AH, 8 AH
NO-LOAD SPEED (GEAR I / II / III)	0-900 / 0-1200 / 0-1500 MIN ⁻¹
IMPACT RATE (GEAR I / II / III)	0-1800 / 2200 / 2800 MIN ⁻¹
TOOL HOLDER	3/4" SQUARE
MAX. TORQUE (SCREW / UNSCREW)	600 - 800 - 1000 / 1600 NM
MAX. BOLT / NUT DIAMETER	M30
WEIGHT	3 KG

CORDLESS HEAVY ROTARY HAMMER
CT28001HX BMC

20VX

- BRUSHLESS MOTOR
- SDS-PLUS CHUCK
- ROTATION SPEED STABILIZATION SYSTEM
- VARIO-LOCK MODE
- ANTI-VIBRATIONS SYSTEM
- SAFETY CLUTCH

ACCESSORIES INCLUDED
Depth stop, Additional handle.



BRUSHLESS

COMPATIBLES BATTERIES	2 AH, 4 AH, 5 AH, 8 AH
NO-LOAD SPEED	0-1400 MIN ⁻¹
IMPACT RATE	0-4500 MIN ⁻¹
SINGLE IMPACT POWER	2,3 J
DRILLING OUTPUT IN CONCRETE	18 MM
DRILLING OUTPUT IN STEEL	13 MM
DRILLING OUTPUT IN WOOD	20 MM
WEIGHT	2,42 KG

CORDLESS HEAVY ROTARY HAMMER
CT28001HX-4 BMC

20VX

- BRUSHLESS MOTOR
- SDS-PLUS CHUCK
- ROTATION SPEED STABILIZATION SYSTEM
- VARIO-LOCK MODE
- ANTI-VIBRATIONS SYSTEM
- SAFETY CLUTCH

ACCESSORIES INCLUDED
Depth stop,
Additional handle,
Batteries 2 pcs, Charger.



BRUSHLESS

BATTERY CAPACITY	4 AH
NO-LOAD SPEED	0-1400 MIN ⁻¹
IMPACT RATE	0-4500 MIN ⁻¹
SINGLE IMPACT POWER	2,3 J
DRILLING OUTPUT IN CONCRETE	18 MM
DRILLING OUTPUT IN STEEL	13 MM
DRILLING OUTPUT IN WOOD	20 MM
WEIGHT	3,1 KG

CORDLESS HEAVY ROTARY HAMMER
CT28001HX IMC

20VX

NEW

- BRUSHLESS MOTOR
- SDS-PLUS CHUCK
- ROTATION SPEED STABILIZATION SYSTEM
- VARIO-LOCK MODE
- ANTI-VIBRATIONS SYSTEM
- SAFETY CLUTCH

ACCESSORIES INCLUDED
Depth stop,
Additional handle.



BRUSHLESS

COMPATIBLES BATTERIES	2 AH, 4 AH, 5 AH, 8 AH
NO-LOAD SPEED	0-1400 MIN ⁻¹
IMPACT RATE	0-4500 MIN ⁻¹
SINGLE IMPACT POWER	2,3 J
DRILLING OUTPUT IN CONCRETE	18 MM
DRILLING OUTPUT IN STEEL	13 MM
DRILLING OUTPUT IN WOOD	20 MM
WEIGHT	2,42 KG



CORDLESS HEAVY ROTARY HAMMER
CT28001HX-5 IMC

20VX

NEW

- BRUSHLESS MOTOR
- SDS-PLUS CHUCK
- ROTATION SPEED STABILIZATION SYSTEM
- VARIO-LOCK MODE
- ANTI-VIBRATIONS SYSTEM
- SAFETY CLUTCH

ACCESSORIES INCLUDED
Depth stop, Additional handle,
Batteries 2 pcs, Charger.



BRUSHLESS

BATTERY CAPACITY	5 AH
NO-LOAD SPEED	0-1400 MIN ⁻¹
IMPACT RATE	0-4500 MIN ⁻¹
SINGLE IMPACT POWER	2,3 J

DRILLING OUTPUT IN CONCRETE	18 MM
DRILLING OUTPUT IN STEEL	13 MM
DRILLING OUTPUT IN WOOD	20 MM
WEIGHT	3,11 KG

CORDLESS ANGLE GRINDER
CT23001-125HX BMC

20VX

- BRUSHLESS MOTOR
- SOFT START
- RESTART PROTECTION
- TWO-POSITION ON / OFF SWITCH
- SAFETY CLUTCH
- QUICK ADJUSTABLE PROTECTIVE CASING

ACCESSORIES INCLUDED
Additional handle, Flange wrench,
Protective casing.



BRUSHLESS

COMPATIBLES BATTERIES	2 AH, 4 AH, 5 AH, 8 AH
RATED SPEED	8000 MIN ⁻¹
MAX. Ø OF CUTTING DISC	125 MM
MAX. Ø OF GRINDING DISC	125 MM
MAX. Ø OF RUBBER SANDING PLATE	125 MM
MAX. Ø OF CIRCULAR WIRE BRUSH	75 MM
MAX. Ø OF CUP WIRE BRUSH	75 MM
SPINDLE THREAD	M14
WEIGHT	1,83 KG

CORDLESS ANGLE GRINDER
CT23001-125HX IMC

20VX

NEW

- BRUSHLESS MOTOR
- SOFT START
- RESTART PROTECTION
- TWO-POSITION ON / OFF SWITCH
- SAFETY CLUTCH
- QUICK ADJUSTABLE PROTECTIVE CASING

ACCESSORIES INCLUDED
Additional handle, Flange wrench,
Protective casing.



BRUSHLESS

COMPATIBLES BATTERIES	2 AH, 4 AH, 5 AH, 8 AH
RATED SPEED	8000 MIN ⁻¹
MAX. Ø OF CUTTING DISC	125 MM
MAX. Ø OF GRINDING DISC	125 MM
MAX. Ø OF RUBBER SANDING PLATE	125 MM
MAX. Ø OF CIRCULAR WIRE BRUSH	75 MM
MAX. Ø OF CUP WIRE BRUSH	75 MM
SPINDLE THREAD	M14
WEIGHT	1,83 KG

CORDLESS ANGLE GRINDER
CT23001-125HX-5 IMC

20VX

NEW

- BRUSHLESS MOTOR
- SOFT START
- RESTART PROTECTION
- TWO-POSITION ON / OFF SWITCH
- SAFETY CLUTCH
- QUICK ADJUSTABLE PROTECTIVE CASING

ACCESSORIES INCLUDED
Additional handle, Flange wrench,
Protective casing.



BRUSHLESS

BATTERY CAPACITY	5 AH
RATED SPEED	8000 MIN ⁻¹
MAX. Ø OF CUTTING DISC	125 MM
MAX. Ø OF GRINDING DISC	125 MM
MAX. Ø OF RUBBER SANDING PLATE	125 MM

MAX. Ø OF CIRCULAR WIRE BRUSH	75 MM
MAX. Ø OF CUP WIRE BRUSH	75 MM
SPINDLE THREAD	M14
WEIGHT	2,52 KG

CORDLESS ANGLE GRINDER
CT23008-125HX

20VX

- BRUSHLESS MOTOR
- SOFT START
- RESTART PROTECTION
- TWO-POSITION ON / OFF SWITCH
- SAFETY CLUTCH

ACCESSORIES INCLUDED
Additional handle, Flange wrench,
Protective casing.



BRUSHLESS

COMPATIBLES BATTERIES	2 AH, 4 AH, 5 AH, 8 AH
RATED SPEED	8500 MIN ⁻¹
MAX. Ø OF CUTTING DISC	125 MM
MAX. Ø OF GRINDING DISC	125 MM
MAX. Ø OF RUBBER SANDING PLATE	125 MM
MAX. Ø OF CIRCULAR WIRE BRUSH	75 MM
MAX. Ø OF CUP WIRE BRUSH	75 MM
MAX. BORE Ø	22,23 MM
SPINDLE THREAD	M14
WEIGHT	1,9 KG

CORDLESS ANGLE GRINDER
CT23008-125HX IMC

20VX

NEW

- BRUSHLESS MOTOR
- VARIABLE SPEED
- SOFT START
- RESTART PROTECTION
- TWO-POSITION ON / OFF SWITCH
- SAFETY CLUTCH

ACCESSORIES INCLUDED
Additional handle, Flange wrench,
Protective casing.



BRUSHLESS

COMPATIBLES BATTERIES	2 AH, 4 AH, 5 AH, 8 AH
RATED SPEED	3000-8500 MIN ⁻¹
MAX. Ø OF CUTTING DISC	125 MM
MAX. Ø OF GRINDING DISC	125 MM
MAX. Ø OF RUBBER SANDING PLATE	125 MM
MAX. Ø OF CIRCULAR WIRE BRUSH	75 MM
MAX. Ø OF CUP WIRE BRUSH	75 MM
MAX. BORE Ø	22,23 MM
SPINDLE THREAD	M14
WEIGHT	1,9 KG

CORDLESS STRAIGHT GRINDER CT23007HX

20VX

- BRUSHLESS MOTOR
- VARIABLE SPEED
- ROTATION SPEED STABILIZATION SYSTEM
- SOFT START
- RESTART PROTECTION
- TWO-POSITION ON / OFF SWITCH
- OVERHEATING AND OVERLOAD PROTECTION SYSTEM
- SOFT GRIP

ACCESSORIES INCLUDED
Wrenches 2 pcs



BRUSHLESS

COMPATIBLES BATTERIES	2 AH, 4 AH, 5 AH, 8 AH
NO-LOAD SPEED	7000-26000 MIN ⁻¹
NUMBER OF RPM STAGES	6
COLLET DIAMETER	6 MM
WEIGHT	1,35 KG

CORDLESS JIGSAW CT25003HX

20VX

- BRUSHLESS MOTOR
- SAW BLADE EASY CHANGE
- 4-STAGE PENDULUM
- STROKE RATE REGULATION
- BREAK RUNDOWN
- METAL BASE PLATE

ACCESSORIES INCLUDED
Allen key, Plastic overlay.



BRUSHLESS

COMPATIBLES BATTERIES	2 AH, 4 AH, 5 AH, 8 AH
STROKE RATE AT NO-LOAD	700-3000 MIN ⁻¹
LENGTH OF STROKE OF THE SAW BLADE	26 MM
MAX. ANGULARITY OF THE BODY (LEFT / RIGHT)	45°/45°
MAX. CUTTING ABILITY IN WOOD	125 MM
MAX. CUTTING ABILITY IN ALUMINUM	20 MM
MAX. CUTTING ABILITY IN STEEL	10 MM
WEIGHT	2,12 KG

CORDLESS JIGSAW CT25003HX BMC

20VX

- BRUSHLESS MOTOR
- SAW BLADE EASY CHANGE
- 4-STAGE PENDULUM
- STROKE RATE REGULATION
- BREAK RUNDOWN
- METAL BASE PLATE

ACCESSORIES INCLUDED
Allen key, Plastic overlay.



BRUSHLESS

COMPATIBLES BATTERIES	2 AH, 4 AH, 5 AH, 8 AH
STROKE RATE AT NO-LOAD	700-3000 MIN ⁻¹
LENGTH OF STROKE OF THE SAW BLADE	26 MM
MAX. ANGULARITY OF THE BODY (LEFT / RIGHT)	45°/45°
MAX. CUTTING ABILITY IN WOOD	85 MM
MAX. CUTTING ABILITY IN ALUMINUM	20 MM
MAX. CUTTING ABILITY IN STEEL	10 MM
WEIGHT	2,12 KG



CORDLESS SABRE SAW CT25007HX

20VX

- ELECTRONIC SPEED ADJUSTMENT
- SAW BLADE EASY CHANGE
- ROTATING REAR HANDLE
- REAR D-HANDLE
- SOFT GRIP

ACCESSORIES INCLUDED
Saw blade.



COMPATIBLES BATTERIES	2 AH, 4 AH, 5 AH, 8 AH
STROKE RATE AT NO-LOAD	0-2800 MIN ⁻¹
STROKE LENGTH	26 MM
CUTTING ABILITY IN WOOD	115 MM
CUTTING ABILITY IN STEEL (PROFILE / PIPE)	5 / 60 MM
WEIGHT	1,92 KG

CORDLESS CIRCULAR SAW CT25002-165HX

20VX

- BRUSHLESS MOTOR
- SOFT START
- BREAK RUNDOWN
- ALUMINIUM BASE PLATE
- OVERHEATING AND OVERLOAD PROTECTION SYSTEM
- HIGH-TORQUE INDICATOR

ACCESSORIES INCLUDED
Allen key, Parallel guide,
Vacuuming connector piece.



BRUSHLESS

COMPATIBLES BATTERIES	2 AH, 4 AH, 5 AH, 8 AH
NO-LOAD SPEED	4800 MIN ⁻¹
CIRCULAR SAW BLADE Ø	165 MM
BORE Ø OF CIRCULAR SAW BLADE	20 MM
MAX. THICKNESS OF CIRCULAR SAW BLADE	1,6 MM
MAX. CUTTING DEPTH BY 90°	57 MM
MAX. CUTTING DEPTH BY 45°	41 MM
MAX. CUTTING DEPTH BY 50°	37 MM
WEIGHT	2,92 KG

CORDLESS CIRCULAR SAW
CT25002-165HX BMC

20VX

- BRUSHLESS MOTOR
- SOFT START
- BREAK RUNDOWN
- ALUMINIUM BASE PLATE
- OVERHEATING AND OVERLOAD PROTECTION SYSTEM
- HIGH-TORQUE INDICATOR



ACCESSORIES INCLUDED
Allen key, Parallel guide, Vacuuming connector piece.

BRUSHLESS

COMPATIBLES BATTERIES	2 AH, 4 AH, 5 AH, 8 AH
NO-LOAD SPEED	4800 MIN ⁻¹
CIRCULAR SAW BLADE Ø	165 MM
BORE Ø OF CIRCULAR SAW BLADE	20 MM
MAX. THICKNESS OF CIRCULAR SAW BLADE	1,6 MM
MAX. CUTTING DEPTH BY 90°	57 MM
MAX. CUTTING DEPTH BY 45°	41 MM
MAX. CUTTING DEPTH BY 50°	37 MM
WEIGHT	2,92 KG

CORDLESS ORBITAL SANDER
CT23010HX

20VX

NEW

- VELCRO FIXING SYSTEM
- VARIABLE SPEED
- DUST EXTRACTION SYSTEM
- SOFT GRIP



ACCESSORIES INCLUDED
Sanding paper, Dust bag.

COMPATIBLES BATTERIES	2 AH, 4 AH, 5 AH, 8 AH
NO-LOAD SPEED	7000-11000 MIN ⁻¹
NO-LOAD OSCILLATIONS RATE	14000-22000 MIN ⁻¹
ORBITAL Ø	1,6 MM
SANDING PLATE SIZE	100 X 145 MM
WEIGHT	0,96 KG

CORDLESS ROTARY SANDER
CT23011HX

20VX

NEW

- VELCRO FIXING SYSTEM
- VARIABLE SPEED
- DUST EXTRACTION SYSTEM
- SOFT GRIP



ACCESSORIES INCLUDED
Sanding paper, Dust bag, Tube for dust removal.

COMPATIBLES BATTERIES	2 AH, 4 AH, 5 AH, 8 AH
NO-LOAD SPEED	7000-11000 MIN ⁻¹
NO-LOAD OSCILLATIONS RATE	14000-22000 MIN ⁻¹
ECCENTRICITY	1,25 MM
SANDING PLATE Ø	120 MM
WEIGHT	1,04 KG

CORDLESS POWER PLANER
CT24001HX

20VX

- SOFT START FUNCTION
- PLANING DEPTH REGULATOR
- V-GROOVE
- REBATING
- SAFETY STOP
- LOCK-OFF FUNCTION
- DUST EXTRACTION SYSTEM
- SOFT GRIP



ACCESSORIES INCLUDED
Dust bag, Allen key, Wrench, Accessories storage container Vertical stop, Bracket, Side stop.

COMPATIBLES BATTERIES	2 AH, 4 AH, 5 AH, 8 AH
NO-LOAD SPEED	16000 MIN ⁻¹
PLANING WIDTH	82 MM
PLANING DEPTH	0-1,5 MM
GROOVING DEPTH	0-9 MM
WEIGHT	2,3 KG

CORDLESS BRAD NAILER
CT61001HX

20VX

- 2 IN 1 U-NAIL / T-NAIL
- ADJUSTABLE IMPACT KNOB
- BELT CLIP
- SOFT GRIP



ACCESSORIES INCLUDED
Staples 500 pcs, Nails 500 pcs, Plastic tip, Hexagonal key.

COMPATIBLES BATTERIES	2 AH, 4 AH, 5 AH, 8 AH
LOAD CAPACITY	100 PCS
STAPLES APPLIED	TYPE 600, 18 GAUGE
STAPLE WIDTH / LENGTH	5,7 / 15-22 MM
NAILS APPLIED	TYPE F, 18GAUGE
NAIL WIDTH / LENGTH	2 / 15, 20, 25, 30, 32 MM
WEIGHT	2,43 KG

CORDLESS ROUTER
CT26010HX

20VX

- BRUSHLESS MOTOR
- VARIABLE SPEED
- SPINDLE LOCK
- DEPTH ADJUSTMENT
- DUST EXTRACTION



BRUSHLESS

COMPATIBLES BATTERIES	2 AH, 4 AH, 5 AH, 8 AH
NO-LOAD SPEED	10000-30000 MIN ⁻¹
COLLET INNER Ø	6 / 8MM (1/4" / 3/8")
STROKE OF THE ROUTER BASE	20 MM
WEIGHT	1,34 KG

CORDLESS MIXER CT26012HX

- BRUSHLESS MOTOR
- M14 TOOL HOLDER
- 2 SPEED SELECTION
- ELECTRONIC SPEED ADJUSTMENT
- OVERHEAT + OVERLOAD PROTECTION
- QUICK CHARGE
- SOFT GRIP

ACCESSORIES INCLUDED

Wrenches 2 pcs, Mixing paddle, Extension rod.



BRUSHLESS

COMPATIBLES BATTERIES	2 AH, 4 AH, 5 AH, 8 AH
NO-LOAD SPEED (GEAR I / II)	0-420 / 0-710 MIN ⁻¹
MAX. STIRRER PADDLE DIAMETER	120 MM
WEIGHT	3,7 KG

CORDLESS BLOWER CT29002HX

- VARIABLE SPEED
- 2 MODES (BLOWER / VACUUM CLEANER)
- STATIONARY USE
- LOCK-ON FUNCTION
- SOFT GRIP

ACCESSORIES INCLUDED

Nozzle, Dust bag.



COMPATIBLES BATTERIES	2 AH, 4 AH, 5 AH, 8 AH
MAX. SUCTION	4,5 KPA
MAX.FLOW RATE	63,5 M/S
WEIGHT	0,98 KG

CORDLESS PRESSURE WASHER CT63002HX

- SELF PRIMING
- ADJUSTABLE STREAM
- LOW PRESSURE ECO MODE
- LOCK-OFF FUNCTION
- TEMPERATURE PROTECTION
- QUICK CHARGER
- SOFT GRIP

ACCESSORIES INCLUDED

Sprayer holder, Tube Quick-release adapter (with valve), Hose, Detergent spray nozzle.



COMPATIBLES BATTERIES	2 AH, 4 AH, 5 AH, 8 AH
MAX. FEED PRESSURE	0,5 MPA
MIN FLOW RATE	<170 L/H
RATED PRESSURE	1,9 / 2,4 MPA
FLOW RATE	160 / 170 L/H
WEIGHT	1,65 KG

20VX

CORDLESS HOT AIR GUN CT60001HX

- FOLDABLE HOOK
- BURN-FREE DETACH MECHANISM
- INTEGRATED LED LIGHT
- LOCK-OFF FUNCTION
- SOFT GRIP

ACCESSORIES INCLUDED

Flat nozzle, Reflector nozzle, Point nozzle.



COMPATIBLES BATTERIES	2 AH, 4 AH, 5 AH, 8 AH
MAX. TEMPERATURE	550 C°
MAX. FLOW RATE	220 L/M
WEIGHT	0,8 KG

20VX

CORDLESS VACUUM CLEANER CT63001HX

- DRY SUCTION
- 500 ML CAPACITY
- SOFT GRIP

ACCESSORIES INCLUDED

Rectangular nozzle, Nozzle brush, Crevice nozzle, Extension tube, Universal holder



COMPATIBLES BATTERIES	2 AH, 4 AH, 5 AH, 8 AH
MAX. SUCTION	3,8 KPA
DUST COLLECTOR CAPABILITY	500 ML
WEIGHT	0,86 KG

20VX

20VX

20VX

CORDLESS WORK LIGHT
CT26008HX

- SWIVEL HEAD
- SOFT GRIP
- BELT CLIP

ACCESSORIES INCLUDED
Belt clip.



COMPATIBLES BATTERIES	2 AH, 4 AH, 5 AH, 8 AH
LED POWER	3 W
LUMINOUS FLUX	180-250 LM
MAX. TILT ANGLE OF SWIVEL HEAD	270°
LIGHTING DURATION, APPROX. (DEPENDING ON BATTERY CAPACITY):	
- BATTERY 2AH / 4AH	~12 H / ~24 H
WEIGHT	0,42 KG



CORDLESS WORK LIGHT
CT26018HX

- SWIVEL HEAD
- 3-MODE SETTING LIGHT

LED POWER	20 W
LUMINOUS FLUX	1000 / 2000 LM
MAX. TILT ANGLE OF SWIVEL HEAD	360°
COLOUR TEMPERATURE	5700±200 K
LIGHTING DURATION, APPROX. (DEPENDING ON BATTERY CAPACITY):	
- BY 1000 LM (BATTERY 2AH / 4AH)	~170 / 340 MIN
- BY 2000 LM (BATTERY 2AH / 4AH)	~85 / 170 MIN
WEIGHT	1,03 KG



CORDLESS SHEARS
CT29001HX

- BRUSHLESS MOTOR
- 3-STEP ADJUSTMENT
- SAFETY LOCK
- OVERLOAD PROTECTION
- SOFT GRIP

ACCESSORIES INCLUDED
Allen key, Socket wrench, Abrasive bar, Protective collar.



BRUSHLESS

COMPATIBLES BATTERIES	2 AH, 4 AH, 5 AH, 8 AH
SHEAR CAPACITY	0-30 MM
MAX SHEAR FORCE	2600 N
WEIGHT	0,82 KG

CORDLESS SHEARS
CT29001HX-2 TB

- BRUSHLESS MOTOR
- 3-STEP ADJUSTMENT
- SAFETY LOCK
- OVERLOAD PROTECTION
- SOFT GRIP

ACCESSORIES INCLUDED
Batteries 2pcs, Allen key, Socket wrench, Abrasive bar, Protective collar, Charger



BRUSHLESS

BATTERY CAPACITY	2 AH
SHEAR CAPACITY	0-30 MM
MAX SHEAR FORCE	2600 N
WEIGHT	1,58 KG

CORDLESS CHAINSAW
CT29006HX

- BRUSHLESS MOTOR
- AUTOMATIC CHAIN LUBRICATION
- OREGON BAR AND CHAIN
- SOFT GRIP

ACCESSORIES INCLUDED
Protective guard of the cutting unit,
Multi-purpose wrench



BRUSHLESS

COMPATIBLES BATTERIES	2 AH, 4 AH, 5 AH, 8 AH
RATED SPEED	4200 MIN ⁻¹
SAW CHAIN SPEED	7,9 M/S
OIL TANK CAPACITY (FOR LUBRICATE THE SAW CHAIN)	115 ML
GUIDE BAR LENGTH	254 MM
SAW CHAIN PARAMETERS(CHAIN PITCH/CHAIN GAUGE)	3/8" / 1/4"
NET WEIGHT (EXCLUDED CUTTING EQUIPMENT)	2,8 KG

CORDLESS BLOWER
CT29013HX

- ELECTRONIC SPEED



COMPATIBLES BATTERIES	2 AH, 4 AH, 5 AH, 8 AH
NO-LOAD SPEED	0-15000 MIN ⁻¹
AIR FLOW RATE	460 M ³ /H
AIR SPEED	140 KM/H
WEIGHT	1,37 KG

CORDLESS LAWN MOWER
CT29018HX

- BRUSHLESS MOTOR
- FIVE CUTTING HEIGHTS
- SAFETY CUT-OUT
- SOFT GRIP



*batteries and charger not included

BRUSHLESS

COMPATIBLES BATTERIES	2 AH, 4 AH, 5 AH, 8 AH
RATED SPEED	2800 / 3400 MIN ⁻¹
CUTTING WIDTH	380 MM
CUTTING HEIGHTS	25 / 39 / 53 / 67 / 80 MM
CAPACITY OF THE GRASS BAG	40 L
WEIGHT	14,67 KG



CORDLESS HEDGE TRIMMER
CT29015HX

- ANTI-VIBRATIONS HANDLE
- LOCK-OFF FUNCTION
- SOFT GRIP

ACCESSORIES INCLUDED
Blade protective cover.



COMPATIBLES BATTERIES	2 AH, 4 AH, 5 AH, 8 AH
IDLING SPEED	3000±200 MIN ⁻¹
STROKE RATE AT NO-LOAD	1200 MIN ⁻¹
BLADE LENGTH (FULL)	560 MM
BLADE LENGTH (WORKING)	510 MM
MAX. Ø OF CUT-OFF BRANCHES	14 MM
WEIGHT	1,98 KG



CORDLESS BRUSH CUTTER
CT29012HX

- ROTATABLE HEAD
- GUIDE WHEEL
- ADJUSTABLE BAR
- SOFT GRIP



COMPATIBLES BATTERIES	2 AH, 4 AH, 5 AH, 8 AH
NO-LOAD SPEED	7500 MIN ⁻¹
MOWING AREA WIDTH (CUTTING LINE)	254 / 305 MM
CUTTING LINE DIAMETER	1,6 MM
WEIGHT	1,9 KG

SPARE REEL
CAG-HTX3

3 pcs

NEW		COMPATIBILITY	CT29012HX
		WIRE DIAMETER	1,6 MM
		WIRE LENGTH	4 M



Storage compartment
for 2 20 V Max. batteries
(2, 4, 5, 8 Ah)



CHARGING TIME

					
		CAC202001X 20 V Max - 2 A	CAC204001X 20 V Max - 4 A	CAC204003X 20 V Max - 4 A	CAC209001X 20 V Max - 9 A
	CAB202013XE 20 V Max - 2 Ah	60 MIN	35 MIN	1 BAT: 35 MIN 2 BAT: 75 MIN	35 MIN
	CAB204014XE 20 V Max - 4 Ah	120 MIN	60 MIN	1 BAT: 60 MIN 2 BAT: 135 MIN	45 MIN
	CAB204015XE 20 V Max - 4 Ah	120 MIN	60 MIN	1 BAT: 60 MIN 2 BAT: 135 MIN	45 MIN
	CAB205014XE 20 V Max - 5 Ah	150 MIN	75 MIN	1 BAT: 75 MIN 2 BAT: 160 MIN	55 MIN
	CAB208016XE CB 20 V Max - 8 Ah	240 MIN	120 MIN	1 BAT: 120 MIN 2 BAT: 250 MIN	50 MIN

BATTERY PACK CAB202013XE

COMPATIBLES CHARGERS:

- CAC202001X
- CAC204001X
- CAC204003X
- CAC209001X



2
Ah

BATTERY CAPACITY	2 AH
BATTERY CHARGING TIME (CAC209001X)	35 MIN
BATTERY CHARGING TIME (CAC204003X)	1 BAT: 35 / 2 BAT: 75 MIN
BATTERY CHARGING TIME (CAC204001X)	35 MIN
BATTERY CHARGING TIME (CAC202001X)	60 MIN
WEIGHT	0,37 KG



BATTERY PACK CAB204014XE

COMPATIBLES CHARGERS:

- CAC202001X
- CAC204001X
- CAC204003X
- CAC209001X



4
Ah

BATTERY CAPACITY	4 AH
BATTERY CHARGING TIME (CAC209001X)	45 MIN
BATTERY CHARGING TIME (CAC204003X)	1 BAT: 60 / 2 BAT: 135 MIN
BATTERY CHARGING TIME (CAC204001X)	60 MIN
BATTERY CHARGING TIME (CAC202001X)	120 MIN
WEIGHT	0,68 KG



BATTERY PACK CAB204015XE

COMPATIBLES CHARGERS:

- CAC202001X
- CAC204001X
- CAC204003X
- CAC209001X



4
Ah

BATTERY CAPACITY	4 AH
BATTERY CHARGING TIME (CAC209001X)	45 MIN
BATTERY CHARGING TIME (CAC204003X)	1 BAT: 60 / 2 BAT: 135 MIN
BATTERY CHARGING TIME (CAC204001X)	60 MIN
BATTERY CHARGING TIME (CAC202001X)	120 MIN
WEIGHT	0,56 KG



BATTERY PACK CAB205014XE

COMPATIBLES CHARGERS:

- CAC202001X
- CAC204001X
- CAC204003X
- CAC209001X



5
Ah

BATTERY CAPACITY	5 AH
BATTERY CHARGING TIME (CAC209001X)	55 MIN
BATTERY CHARGING TIME (CAC204003X)	1 BAT: 75 / 2 BAT: 160 MIN
BATTERY CHARGING TIME (CAC204001X)	75 MIN
BATTERY CHARGING TIME (CAC202001X)	150 MIN
WEIGHT	0,69 KG



BATTERIA CAB208016XE CB

CARICABATTERIE COMPATIBILI:

- CAC202001X
- CAC204001X
- CAC204003X
- CAC209001X

8
Ah



BATTERY CAPACITY	8 AH
BATTERY CHARGING TIME (CAC209001X)	50 MIN
BATTERY CHARGING TIME (CAC204003X)	1 BAT: 120 / 2 BAT: 250 MIN
BATTERY CHARGING TIME (CAC204001X)	120 MIN
BATTERY CHARGING TIME (CAC202001X)	240 MIN
WEIGHT	1 KG

20VX

BATTERY CHARGER CAC202001X

COMPATIBLES BATTERIES:

- CAB202013XE
- CAB204014XE
- CAB204015XE
- CAB205014XE
- CAB208016XE



RATED POWER	55 W
OUTPUT VOLTAGE	18 - 20 V MAX.
AMPERAGE AT VOLTAGE 220-230 V	2 A
COMPARISON OF CHARGING TIMES	SEE TABLE PAGE 22
WEIGHT	0,39 KG
CAB202013XE (2 AH) CHARGING TIME	60 MIN
CAB204014XE (4 AH) CHARGING TIME	120 MIN
CAB204015XE (4 AH) CHARGING TIME	120 MIN
CAB205014XE (5 AH) CHARGING TIME	150 MIN
CAB208016XE (8 AH) CHARGING TIME	240 MIN

BATTERY CHARGER CAC204001X

COMPATIBLES BATTERIES:

- CAB202013XE
- CAB204014XE
- CAB204015XE
- CAB205014XE
- CAB208016XE



RATED POWER	100 W
OUTPUT VOLTAGE	18 - 20 V MAX.
AMPERAGE AT VOLTAGE 220-230 V	4 A
COMPARISON OF CHARGING TIMES	SEE TABLE PAGE 22
WEIGHT	0,5 KG
CAB202013XE (2 AH) CHARGING TIME	35 MIN
CAB204014XE (4 AH) CHARGING TIME	60 MIN
CAB204015XE (4 AH) CHARGING TIME	60 MIN
CAB205014XE (5 AH) CHARGING TIME	75 MIN
CAB208016XE (8 AH) CHARGING TIME	120 MIN

20VX

CARICABATTERIE CAC204003X

BATTERIE COMPATIBILI:

- CAB202013XE
- CAB204014XE
- CAB204015XE
- CAB205014XE
- CAB208016XE



RATED POWER	105 W
OUTPUT VOLTAGE	18 - 20 V MAX.
AMPERAGE AT VOLTAGE 220-230 V	4 A
COMPARISON OF CHARGING TIMES	SEE TABLE PAGE 22
WEIGHT	0,67 KG
CAB202013XE (2 AH) CHARGING TIME	1 BAT: 35 MIN 2 BAT: 75 MIN
CAB204014XE (4 AH) CHARGING TIME	1 BAT: 60 MIN 2 BAT: 135 MIN
CAB204015XE (4 AH) CHARGING TIME	11 BAT: 60 MIN 2 BAT: 135 MIN
CAB205014XE (5 AH) CHARGING TIME	1 BAT: 75 MIN 2 BAT: 160 MIN
CAB208016XE (8 AH) CHARGING TIME	1 BAT: 120 MIN 2 BAT: 250 MIN

20VX

BATTERY CHARGER CAC209001X

COMPATIBLES BATTERIES:

- CAB202013XE
- CAB204014XE
- CAB204015XE
- CAB205014XE
- CAB208016XE



RATED POWER	250 W
OUTPUT VOLTAGE	18 - 20 V MAX.
AMPERAGE AT VOLTAGE 220-230 V	9 A
COMPARISON OF CHARGING TIMES	SEE TABLE PAGE 22
WEIGHT	0,93 KG
CAB202013XE (2 AH) CHARGING TIME	35 MIN
CAB204014XE (4 AH) CHARGING TIME	45 MIN
CAB204015XE (4 AH) CHARGING TIME	45 MIN
CAB205014XE (5 AH) CHARGING TIME	55 MIN
CAB208016XE (8 AH) CHARGING TIME	50 MIN

20VX

USB CHARGER CAU02X

COMPATIBLES BATTERIES:

- CAB202013XE
- CAB204014XE
- CAB204015XE
- CAB205014XE
- CAB208016XE



OUTPUT VOLTAGE USB1 (TYPE A)	5 V (1 A)
OUTPUT VOLTAGE USB2 (TYPE A)	5 V (1 A)
BATTERY TYPE	LITHIUM-ION
WEIGHT	0,85 KG

20VX

STACKABLE CASES SYSTEM

TO TRANSPORT
AND ORGANIZE
YOUR TOOLS

STACKABLE POLYPROPYLENE CASES SYSTEM.
3 DIFFERENT SIZES. CONVENIENT CASE TROLLEY
WITH WHEELS. A WHEELED BASE WITH 100 KG
MAXIMUM LOAD COMPLETES THE ASSORTMENT.



CART WITH STACKABLE CASE

CTQ-VRT

28 litri

NOVITÀ

- STACKABLE
- PP MATERIAL
- TELESCOPIC ALUMINUM HANDLE
- 2 RUBBER-COATED WHEELS
- IP54 PROTECTION
- POLYAMIDE SIDE CONNECTORS



ADJUSTABLE HANDLE



CLOSING CLASPS



SAFETY LOCKS



LENGTH INT. / EXT.	30,8 / 45 CM
WIDTH INT. / EXT.	21 / 39 CM
HEIGHT INT. / EXT.	29,6 / 69 CM
WEIGHT	4,9 KG

STACKABLE CASE

CTQ-VM

- STACKABLE
- PP MATERIAL
- ERGONOMIC FRONT AND LID HANDLE
- IP54 PROTECTION
- POLYAMIDE SIDE CONNECTORS



LENGTH INT. / EXT.	36 / 45 CM
WIDTH INT. / EXT.	24,5 / 33 CM
HEIGHT INT. / EXT.	12 / 17 CM
WEIGHT	2,25 KG

12 Lt

NEW

STACKABLE CASE

CTQ-VL

- STACKABLE
- PP MATERIAL
- ERGONOMIC FRONT AND LID HANDLE
- IP54 PROTECTION
- POLYAMIDE SIDE CONNECTORS



LENGTH INT. / EXT.	36 / 45 CM
WIDTH INT. / EXT.	24,5 / 33 CM
HEIGHT INT. / EXT.	19 / 24 CM
WEIGHT	2,65 KG

19 Lt

NEW



ROLL PLATE FOR STACKABLE CASE

CTQ-PR

- PP MATERIAL
- 360° TURNABLE WHEELS
- 2 LOCKABLE WHEELS
- IP54 PROTECTION
- ALUMINUM BRACKETS



MAX. LOAD	100 KG
LENGTH	50,6 CM
WIDTH	32,5 CM
HEIGHT	14 CM
WEIGHT	2,85 KG

up to 100 kg

NEW

TOOLS BAG

CP-TBT-B-18

- 1680D POLYESTER FABRIC
- BELT CLIP

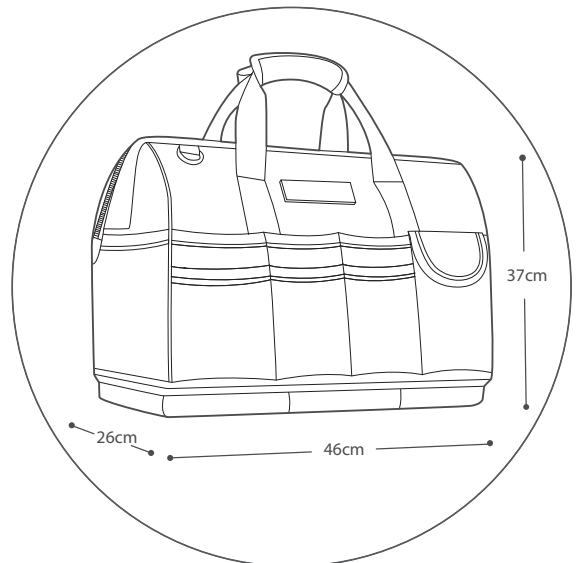

IMPACT WRENCH

CT12018

- 1/2" SQUARE TOOL HOLDER
- REVERSE FUNCTION
- SOFT GRIP



900 W

AMPERAGE AT VOLTAGE 220-230 V	4.3 A
NO-LOAD SPEED	2100 MIN ⁻¹
IMPACT RATE	2700 MIN ⁻¹
MAX. TORQUE	320 NM
TOOL HOLDER	1/2" SQUARE
MIN. / MAX. BOLT AND NUT DIAMETER	M8-M24
WEIGHT	3,5 KG

DRILL

CT10113

- SPINDLE AUTOMATIC LOCKING
- KEYLESS CHUCK
- STEP SPEED SELECTION
- ELECTRONIC SPEED ADJUSTMENT
- VARIABLE TORQUE
- 2 FUNCTION MODES (SCREWDRIVING / DRILLING)
- REVERSE FUNCTION
- INTEGRATED LED LIGHT



280 W

AMPERAGE AT VOLTAGE 220-230 V	1.2 A
NO-LOAD SPEED (GEAR I / II)	0-350 / 0-1400 MIN ⁻¹
TURNDOWN OF ROTATION TORQUE	0,8-22 NM
CHUCK TIGHTENING RANGE	0,8-10 MM
DRILLING OUTPUT IN STEEL	10 / 10 MM
DRILLING OUTPUT IN WOOD	16 / 20 MM
WEIGHT	1,36 KG

DRILL

CT10151

- KEYLESS CHUCK
- STEP SPEED SELECTION
- ELECTRONIC SPEED ADJUSTMENT
- VARIABLE TORQUE
- 2 FUNCTION MODES (SCREWDRIVING / DRILLING)
- REVERSE FUNCTION
- LOCK-ON FUNCTION
- INTEGRATED LED LIGHT
- SOFT GRIP



230 W

AMPERAGE AT VOLTAGE 220-230 V	1 A
NO-LOAD SPEED (GEAR I / II)	0-450 / 0-1600 MIN ⁻¹
TURNDOWN OF ROTATION TORQUE	0,7-30 NM
CHUCK TIGHTENING RANGE	0,8-10 MM
DRILLING OUTPUT IN STEEL	8 / 8 MM
DRILLING OUTPUT IN WOOD	25 / 25 MM
WEIGHT	1 KG

DRILL

CT10126C

- KEYLESS CHUCK
- VARIABLE SPEED
- ELECTRONIC SPEED ADJUSTMENT
- REVERSE FUNCTION
- LOCK-ON FUNCTION
- BELT CLIP



400 W

AMPERAGE AT VOLTAGE 220-230 V	1.85 A
NO-LOAD SPEED	0-3000 MIN ⁻¹
CHUCK TIGHTENING RANGE	0,8-10 MM
DRILLING OUTPUT IN STEEL	10 MM
DRILLING OUTPUT IN WOOD	20 MM
WEIGHT	1,4 KG

DRILL

CT10143-13C

- KEYLESS CHUCK WITH LOCKING FUNCTION
- VARIABLE SPEED
- ELECTRONIC SPEED ADJUSTMENT
- REVERSE FUNCTION
- LOCK-ON FUNCTION
- BELT CLIP
- SOFT GRIP



550 W

AMPERAGE AT VOLTAGE 220-230 V	2.65 A
NO-LOAD SPEED	0-2800 MIN ⁻¹
CHUCK TIGHTENING RANGE	2-13 MM
DRILLING OUTPUT IN STEEL	13 MM
DRILLING OUTPUT IN WOOD	25 MM
WEIGHT	1,42 KG

DRILL AND IMPACT DRILL

CT10152F

- KEYLESS CHUCK
- STEP SPEED SELECTION
- ELECTRONIC SPEED ADJUSTMENT
- VARIABLE TORQUE
- 3 FUNCTION MODES (SCREWDRIVING / DRILLING / CHISELING)
- REVERSE FUNCTION
- INTEGRATED LED LIGHT
- SOFT GRIP

ACCESSORIES INCLUDED

Additional handle



420 W

IMPACT DRILL

CT10128C

- KEYLESS CHUCK WITH LOCKING FUNCTION
- VARIABLE SPEED
- ELECTRONIC SPEED ADJUSTMENT
- 2 FUNCTION MODES (DRILLING / IMPACT DRILLING)
- REVERSE FUNCTION
- LOCK-ON FUNCTION
- SOFT GRIP



600 W

AMPERAGE AT VOLTAGE 220-230 V	1.8 A
NO-LOAD SPEED (GEAR I / ID)	0-480 / 0-1800 MIN ⁻¹
IMPACT RATE (GEAR I / ID)	0-7200 / 0-27000 MIN ⁻¹
CHUCK TIGHTENING RANGE	2-13 MM
DRILLING OUTPUT IN STEEL	13 / 13 MM
DRILLING OUTPUT IN WOOD	35 / 35 MM
WEIGHT	1,66 KG

AMPERAGE AT VOLTAGE 220-230 V	2.8 A
NO-LOAD SPEED	0-2800 MIN ⁻¹
IMPACT RATE	0-44800 MIN ⁻¹
CHUCK TIGHTENING RANGE	2-13 MM
DRILLING OUTPUT IN CONCRETE	13 MM
DRILLING OUTPUT IN STEEL	13 MM
DRILLING OUTPUT IN WOOD	20 MM
WEIGHT	1,7 KG

IMPACT DRILL WITH SET OF TOOLS AND ACCESSORIES

CK10-XA98C

- KEYLESS CHUCK
- VARIABLE SPEED
- ELECTRONIC SPEED ADJUSTMENT
- 2 FUNCTION MODES (DRILLING / IMPACT DRILLING)

- REVERSE FUNCTION
- LOCK-ON FUNCTION
- SOFT GRIP

600 W

Magnetic bit holders

60 mm

Sockets adapter

25 mm

10 pz bits (25 mm)

- ⊖ 2 pcs: SL4 | SL6
- ⊕ 2 pcs: PH1 | PH2
- ⊗ 2 pcs: PZ1 | PZ2
- ⊙ 2 pcs: H4 | H5
- ⊛ 2 pcs: T20 | T25

Screws and plugs

- 30 pcs screws: ST3.5 (x10), ST4 (x10), ST5 (x10)
- 30 pcs plugs: 6 (x10), 8 (x10), 10 (x10)

Additional handle

Universal plier

150 mm

Adjustable wrench

150 mm

6 pcs sockets 1/4"

⊙ 5 | 6 | 8 | 9 | 10 | 11 mm

Depth stop

Level

230 mm

Screwdriver

SL5x100 mm

Screwdriver

PH1x100 mm

12 pz drill bits

- Metal: 2 | 3 | 4 | 5 | 6 mm
- Masonry: 6 | 8 | 10 mm
- Wood: 4 | 5 | 6 | 8 mm

Impact drill

CT10128C

Carpenter hammer

250 g

Measuring tape

3 m x 16 mm

AMPERAGE AT VOLTAGE 220-230 V	2.8 A
NO-LOAD SPEED	0-2800 MIN ⁻¹
IMPACT RATE	0-44800 MIN ⁻¹
CHUCK TIGHTENING RANGE	2-13 MM

DRILLING OUTPUT IN CONCRETE	13 MM
DRILLING OUTPUT IN STEEL	13 MM
DRILLING OUTPUT IN WOOD	20 MM
WEIGHT	1,7 KG

IMPACT DRILL

CT10129C

- KEYLESS CHUCK WITH LOCKING FUNCTION
- VARIABLE SPEED
- ELECTRONIC SPEED ADJUSTMENT
- 2 FUNCTION MODES (DRILLING / IMPACT DRILLING)
- REVERSE FUNCTION
- LOCK-ON FUNCTION
- SOFT GRIP

ACCESSORIES INCLUDED

Depth stop, Additional handle.



750 W

IMPACT DRILL

CT10130C

- METAL KEYLESS CHUCK
- VARIABLE SPEED
- ELECTRONIC SPEED ADJUSTMENT
- 2 FUNCTION MODES (DRILLING / IMPACT DRILLING)
- REVERSE FUNCTION
- LOCK-ON FUNCTION
- SOFT GRIP

ACCESSORIES INCLUDED

Depth stop, Additional handle.



810 W

AMPERAGE AT VOLTAGE 220-230 V	3.5 A
NO-LOAD SPEED	0-2800 MIN ⁻¹
IMPACT RATE	0-44800 MIN ⁻¹
CHUCK TIGHTENING RANGE	2-13 MM
DRILLING OUTPUT IN CONCRETE	16 MM
DRILLING OUTPUT IN STEEL	13 MM
DRILLING OUTPUT IN WOOD	30 MM
WEIGHT	1,9 KG

AMPERAGE AT VOLTAGE 220-230 V	3.9 A
NO-LOAD SPEED	0-2800 MIN ⁻¹
IMPACT RATE	0-44800 MIN ⁻¹
CHUCK TIGHTENING RANGE	2-13 MM
DRILLING OUTPUT IN CONCRETE	16 MM
DRILLING OUTPUT IN STEEL	13 MM
DRILLING OUTPUT IN WOOD	30 MM
WEIGHT	2,2 KG



IMPACT DRILL

CT10032

- GEAR RIM CHUCK
- VARIABLE SPEED
- STEP SPEED SELECTION
- ELECTRONIC SPEED ADJUSTMENT
- 2 FUNCTION MODES (DRILLING / IMPACT DRILLING)
- REVERSE FUNCTION
- LOCK-ON FUNCTION
- SOFT GRIP

ACCESSORIES INCLUDED

Depth stop, Additional handle, Drill chuck key.



1050 W

AMPERAGE AT VOLTAGE 220-230 V	4.9 A
NO-LOAD SPEED (GEAR I / II)	0-900 / 0-2500 MIN ⁻¹
IMPACT RATE (GEAR I / II)	0-14400 / 0-40000 MIN ⁻¹
CHUCK TIGHTENING RANGE	3-16 MM
DRILLING OUTPUT IN CONCRETE	20/16 MM
DRILLING OUTPUT IN STEEL	13/13 MM
DRILLING OUTPUT IN WOOD	40/30 MM
WEIGHT	3,4 KG

LOW SPEED DRILL

CT10148

- GEAR RIM CHUCK
- VARIABLE SPEED
- ELECTRONIC SPEED ADJUSTMENT
- 2 FUNCTION MODES (STIRRING / DRILLING)
- REVERSE FUNCTION
- LOCK-ON FUNCTION

ACCESSORIES INCLUDED

Depth stop, Additional handle, Drill chuck key.



1200 W

Amperage at voltage 220-230 V	5.45 A
No-load speed	0-1000 min ⁻¹
Chuck tightening range	3-16 mm
Drilling output in steel	16 mm
Drilling output in wood	40 mm
Max. mixing paddle diameter	130 mm
Weight	3,2 kg

MIXER

CT10049

- M 14 TOOL HOLDER THREAD
- SOFT START
- VARIABLE SPEED
- STEP SPEED SELECTION
- LOCK-ON FUNCTION
- SOFT GRIP

ACCESSORIES INCLUDED

Mixing paddle, Extension rod, Wrench.



1100 W

Amperage at voltage 220-230 V	4.8 A
No-load speed (gear I / II)	130-450 / 245-850 min ⁻¹
Tool holder	M14
Mixing paddle diameter	120 mm
Weight	4,1 kg

MIXER

CT10182

- M 14 TOOL HOLDER THREAD
- SOFT START
- VARIABLE SPEED
- STEP SPEED SELECTION
- LOCK-ON FUNCTION
- SOFT GRIP

ACCESSORIES INCLUDED

Mixing paddle, Extension rod, Wrench.



1600 W

NEW

Amperage at voltage 220-240 V	6.9 A
No-load speed (gear I / II)	180-480 / 300-750 min ⁻¹
Tool holder	M14

Max. mixing paddle diameter	160 mm
Weight	4,9 kg

LIGHT ROTARY HAMMER

CT18180 BMC

- SDS-PLUS CHUCK
- EXTRA GEAR RIM CHUCK WITH SDS PLUS ADAPTER
- ELECTRONIC SPEED ADJUSTMENT
- 3 FUNCTIONS MODE (DRILLING / IMPACT DRILLING / CHISELLING)
- REVERSE FUNCTION
- VARIO-LOCK FUNCTION
- SAFETY CLUTCH
- LOCK-ON FUNCTION
- SOFT GRIP

ACCESSORIES INCLUDED

Depth stop, Additional handle, Drill bits 3 pcs, Gear rim chuck (with SDS PLUS shank), Drill chuck key, Dust collector.



650 W

Amperage at voltage 220-230 V	2.7 A
No-load speed	0-1400 min ⁻¹
Impact rate	0-4400 min ⁻¹
Single impact power	1,7 J
Drilling output in concrete	20 mm
Drilling output in steel	13 mm
Drilling output in wood	40 mm
Weight	2,3 kg

LIGHT ROTARY HAMMER

CT18108 BMC

- SDS-PLUS CHUCK
- ELECTRONIC SPEED ADJUSTMENT
- 3 FUNCTIONS MODE (DRILLING / IMPACT DRILLING / CHISELLING)
- VARIO-LOCK MODE
- REVERSE FUNCTION
- SAFETY CLUTCH
- LOCK-ON FUNCTION
- SOFT GRIP

ACCESSORIES INCLUDED

Depth stop, Additional handle, Drill bits 3 pcs, Point chisel, Flat chisel, Gear rim chuck (with SDS PLUS shank), Drill chuck key.



800 W

AMPERAGE AT VOLTAGE 220-230 V	3,8 A
NO-LOAD SPEED	0-1200 MIN ⁻¹
IMPACT RATE	0-5300 MIN ⁻¹
SINGLE IMPACT POWER	3,4 J
DRILLING OUTPUT IN CONCRETE	26 MM
DRILLING OUTPUT IN STEEL	13 MM
DRILLING OUTPUT IN WOOD	40 MM
WEIGHT	2,8 KG



HEAVY ROTARY HAMMER

CT18116 BMC

- SDS-PLUS CHUCK
- 3 MODES (DRILLING / IMPACT DRILLING / CHISELLING)
- ANTI-VIBRATIONS SYSTEM
- SAFETY CLUTCH
- SOFT GRIP

ACCESSORIES INCLUDED

Depth stop, Additional handle, Drill bits 3 pcs, Point chisel, Flat chisel, Dust collector, Container with lubricant, Flange wrench.



1050 W

AMPERAGE AT VOLTAGE 220-230 V	4,9 A
NO-LOAD SPEED	750 MIN ⁻¹
IMPACT RATE	2800 MIN ⁻¹
SINGLE IMPACT POWER	4,8 J
DRILLING OUTPUT IN CONCRETE	32 MM
DRILLING OUTPUT IN STEEL	13 MM
DRILLING OUTPUT IN WOOD	40 MM
WEIGHT	5 KG

HEAVY ROTARY HAMMER

CT18118V BMC

- SDS-MAX CHUCK
- VARIABLE SPEED
- 2 MODES (IMPACT DRILLING / CHISELLING)
- VARIO-LOCK MODE
- ANTI-VIBRATIONS SYSTEM
- SAFETY CLUTCH
- SOFT GRIP

ACCESSORIES INCLUDED

Depth stop, Additional handle, Drill bits 3 pcs, Point chisel, Flat chisel, Dust collector, Container with lubricant.



1250 W

AMPERAGE AT VOLTAGE 220-230 V	5,6 A
NO-LOAD SPEED	0-410 MIN ⁻¹
IMPACT RATE	0-3000 MIN ⁻¹
SINGLE IMPACT POWER	0-10 J
DRILLING OUTPUT IN CONCRETE	40 MM
WEIGHT	7 KG

HEAVY ROTARY HAMMER

CT18216V BMC

1500 W

NEW

- BRUSHLESS MOTOR
- SDS-MAX CHUCK
- VARIABLE SPEED
- 2 FUNCTION MODES (IMPACT DRILLING / CHISELING)
- VARIO-LOCK MODE
- ANTI-VIBRATIONS SYSTEM
- SAFETY CLUTCH
- SOFT GRIP

ACCESSORIES INCLUDED
Container with lubricant,
Additional handle.



BRUSHLESS

AMPERAGE AT VOLTAGE 220-230 V	7.2 A
NO-LOAD SPEED	170-330 MIN ⁻¹
IMPACT RATE	1500-3000 MIN ⁻¹
SINGLE IMPACT POWER	15 J
CHUCK TYPE	SDS-MAX
DRILLING OUTPUT IN CONCRETE	48 MM
WEIGHT	9 KG

Drilling speed

Test effettuato su calcestruzzo standard C35

CROWN mod. CT18216V

competitor model similar

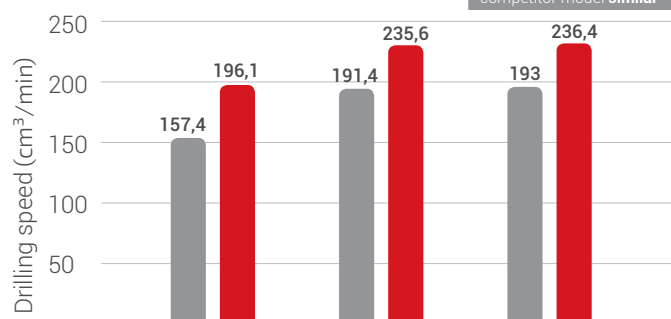

FOCUS ON

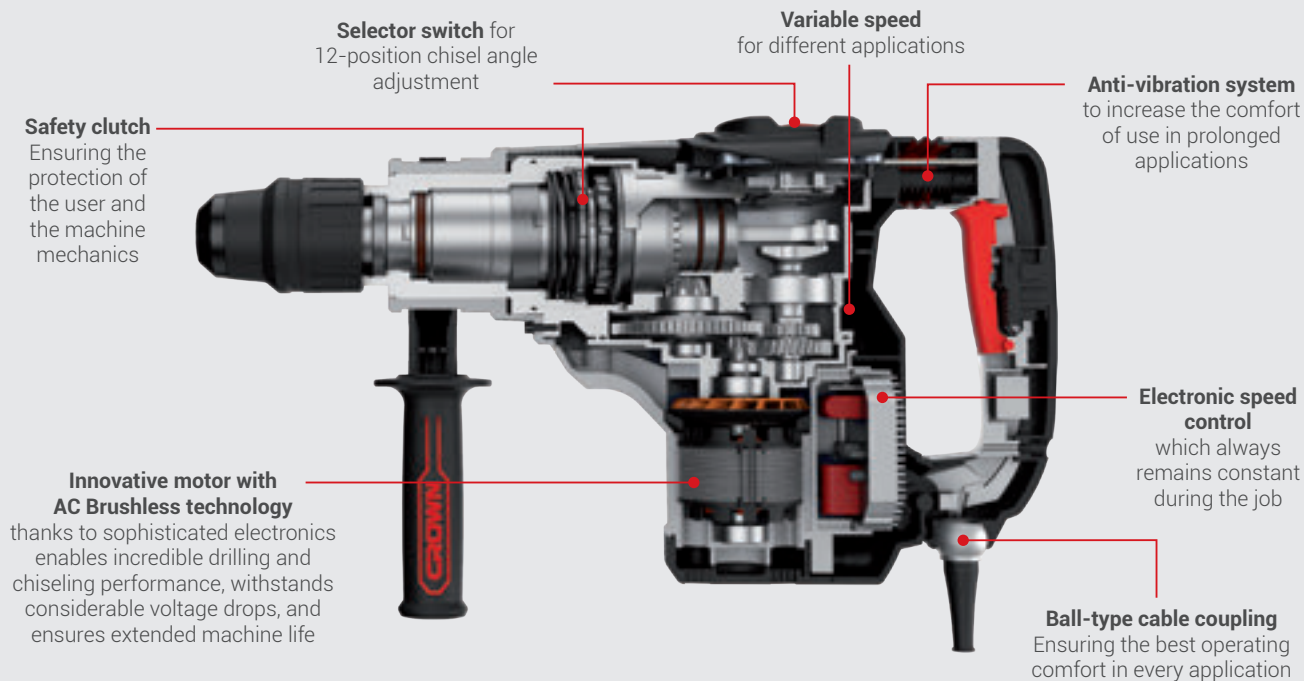

HEAVY ROTARY HAMMER

CT18190 BMC

1700 W

- SDS-MAX CHUCK
- VARIABLE SPEED
- 2 FUNCTION MODES (IMPACT DRILLING / CHISELING)
- VARIO-LOCK MODE
- ANTI-VIBRATIONS SYSTEM
- SAFETY CLUTCH
- POWER LIGHT INDICATOR
- CARBON BRUSH REPLACEMENT INDICATOR LIGHT

ACCESSORIES INCLUDED

Additional handle, Container with lubricant, Carbon brush.



AMPERAGE AT VOLTAGE 220-240 V	8 A
NO-LOAD SPEED	100-220 MIN ⁻¹
IMPACT RATE	1750-2150 MIN ⁻¹
SINGLE IMPACT POWER	5-19 J
CHUCK TYPE	SDS-MAX
DRILLING OUTPUT IN CONCRETE	55 MM
WEIGH	10 KG



HAMMER

CT18221 BMC

950 W

NEW

- SDS-PLUS CHUCK
- ANTI-VIBRATIONS SYSTEM
- POWER LIGHT INDICATOR
- VARIO-LOCK MODE
- SOFT GRIP

ACCESSORIES INCLUDED

Additional handle, Container with lubricant, Carbon brush.



AMPERAGE AT VOLTAGE 220-240 V	3.2 A
IMPACT RATE	4300 MIN ⁻¹
SINGLE IMPACT POWER	5 J
CHUCK TYPE	SDS-PLUS
WEIGHT	3,9 KG

HAMMER
CT18173M BMC

1300 W

- SDS-MAX CHUCK
- LOCK-ON FUNCTION
- SOFT GRIP

ACCESSORIES INCLUDED

Additional handle, Point chisel, Flat chisel, Flange wrench, Tube with lubricant, Carbon brush.



AMPERAGE AT VOLTAGE 220-230 V	5.9 A
IMPACT RATE	2400 MIN ⁻¹
SINGLE IMPACT POWER	20 J
WEIGHT	7,5 KG

HAMMER
CT18123V BMC

1500 W

- SDS-MAX CHUCK
- IMPACT RATE REGULATION
- VARIO-LOCK MODE
- ANTI-VIBRATIONS SYSTEM
- CARBON BRUSH REPLACEMENT INDICATOR LIGHT
- SOFT GRIP

ACCESSORIES INCLUDED

Depth stop, Additional handle, Drill bits 3pcs, Point chisel, Flat chisel, Dust collector, Container with lubricant.



AMPERAGE AT VOLTAGE 220-230 V	6.5 A
IMPACT RATE	900-1900 MIN ⁻¹
SINGLE IMPACT POWER	8-25 J
WEIGHT	10,96 KG

BREAKER
CT18124 BMC

1750 W

- HEX-30 TOOL HOLDER
- ANTI-VIBRATIONS SYSTEM
- CARBON BRUSH REPLACEMENT INDICATOR LIGHT
- POWER LIGHT INDICATOR
- SOFT GRIP

ACCESSORIES INCLUDED

Additional handle, Point chisel, Flat chisel, Container with lubricant, Allen key.



AMPERAGE AT VOLTAGE 220-230 V	8.7 A
IMPACT RATE	1600 MIN ⁻¹
SINGLE IMPACT POWER	48 J
WEIGHT	14,5 KG



WALL CHASER
CT13525-125

1500 W

- DRY CUTTING
- SPINDLE LOCK
- CUTTING DEPTH ADJUSTMENT
- LOCK-ON FUNCTION
- DUST EXTRACTION SYSTEM
- SOFT GRIP

ACCESSORI INCLUSI

Diamond cutting disc 2 pcs, Allen key, Flange wrench, Allen key with handle, Break-out tool.



AMPERAGE AT VOLTAGE 220-230 V	7 A
RATED SPEED	8500 MIN ⁻¹
Ø OF DIAMOND CUTTING DISC	125 MM
BORE Ø OF DIAMOND CUTTING DISC	22,23 MM
MAX. THICKNESS OF DIAMOND CUTTING DISC	2,2 MM
CUTTING DEPTH	5-29 MM
CUTTING WIDTH	8-30 MM
SPINDLE THREAD	M14
WEIGHT	4,85 KG

ANGLE GRINDER CT13501-115R

650 W

- M 14 SPINDLE THREAD
- SOFT START
- SPINDLE LOCK
- RESTART PROTECTION
- TWO-POSITION ON / OFF SWITCH

ACCESSORIES INCLUDED
Flange wrench, Additional handle,
Protective casing.



RATED SPEED	11000 MIN ⁻¹
AMPERAGE AT VOLTAGE 220-230 V	3 A
MAX. Ø OF CUTTING DISC	115 MM
MAX. Ø OF GRINDING DISC	115 MM
MAX. Ø OF RUBBER SANDING PLATE	115 MM
MAX. Ø OF CIRCULAR WIRE BRUSH	75 MM
MAX. Ø OF CUP WIRE BRUSH	75 MM
WEIGHT	1,8 KG

ANGLE GRINDER CT13499-115R

720 W

- M 14 SPINDLE THREAD
- SOFT START
- SPINDLE LOCK
- RESTART PROTECTION
- TWO-POSITION ON / OFF SWITCH

ACCESSORIES INCLUDED
Flange wrench, Additional handle,
Protective casing.



RATED SPEED	11000 MIN ⁻¹
AMPERAGE AT VOLTAGE 220-230 V	3.3 A
MAX. Ø OF CUTTING DISC	115 MM
MAX. Ø OF GRINDING DISC	115 MM
MAX. Ø OF RUBBER SANDING PLATE	115 MM
MAX. Ø OF CIRCULAR WIRE BRUSH	75 MM
MAX. Ø OF CUP WIRE BRUSH	75 MM
WEIGHT	1,85 KG

ANGLE GRINDER CT13499-125R

720 W

- M 14 SPINDLE THREAD
- SOFT START
- SPINDLE LOCK
- RESTART PROTECTION
- TWO-POSITION ON / OFF SWITCH

ACCESSORIES INCLUDED
Flange wrench, Additional handle,
Protective casing.



RATED SPEED	11000 MIN ⁻¹
AMPERAGE AT VOLTAGE 220-230 V	3.3 A
MAX. Ø OF CUTTING DISC	125 MM
MAX. Ø OF GRINDING DISC	125 MM
MAX. Ø OF RUBBER SANDING PLATE	125 MM
MAX. Ø OF CIRCULAR WIRE BRUSH	75 MM
MAX. Ø OF CUP WIRE BRUSH	75 MM
WEIGHT	1,9 KG



ANGLE GRINDER CT13295

860 W

- M 14 SPINDLE THREAD
- SOFT START
- SPINDLE LOCK
- RESTART PROTECTION
- TWO-POSITION ON / OFF SWITCH

ACCESSORIES INCLUDED
Flange wrench, Additional handle,
Protective casing.



RATED SPEED	11000 MIN ⁻¹
AMPERAGE AT VOLTAGE 220-230 V	3.89 A
MAX. Ø OF CUTTING DISC	115 MM
MAX. Ø OF GRINDING DISC	115 MM
MAX. Ø OF RUBBER SANDING PLATE	115 MM
MAX. Ø OF CIRCULAR WIRE BRUSH	75 MM
MAX. Ø OF CUP WIRE BRUSH	75 MM
WEIGHT	2,05 KG

ANGLE GRINDER CT13571-115R

900 W

NEW

- M 14 SPINDLE THREAD
- SPINDLE LOCK
- RESTART PROTECTION
- TWO-POSITION ON / OFF SWITCH

ACCESSORIES INCLUDED
Flange wrench, Additional handle,
Protective casing.



RATED SPEED	12000 MIN ⁻¹
AMPERAGE AT VOLTAGE 220-230 V	3.9 A
MAX. Ø OF CUTTING DISC	115 MM
MAX. Ø OF GRINDING DISC	115 MM
MAX. Ø OF RUBBER SANDING PLATE	115 MM
MAX. Ø OF CIRCULAR WIRE BRUSH	75 MM
MAX. Ø OF CUP WIRE BRUSH	75 MM
WEIGHT	1,71 KG

ANGLE GRINDER CT13571-125R

- M 14 SPINDLE THREAD
- SPINDLE LOCK
- RESTART PROTECTION
- TWO-POSITION ON / OFF SWITCH

ACCESSORIES INCLUDED
Flange wrench, Additional handle,
Protective casing.



SMALL BODY

900 W

NEW

RATED SPEED	12000 MIN ⁻¹
AMPERAGE AT VOLTAGE 220-230 V	3.9 A
MAX. Ø OF CUTTING DISC	125 MM
MAX. Ø OF GRINDING DISC	125 MM

MAX. Ø OF RUBBER SANDING PLATE	125 MM
MAX. Ø OF CIRCULAR WIRE BRUSH	75 MM
MAX. Ø OF CUP WIRE BRUSH	75 MM
WEIGHT	1,75 KG

ANGLE GRINDER CT13502-115R

- M 14 SPINDLE THREAD
- SOFT START
- SPINDLE LOCK
- RESTART PROTECTION
- TWO-POSITION ON / OFF SWITCH

ACCESSORIES INCLUDED
Flange wrench, Additional handle,
Protective casing.



1010 W

RATED SPEED	11000 MIN ⁻¹
AMPERAGE AT VOLTAGE 220-230 V	4.5 A
MAX. Ø OF CUTTING DISC	115 MM
MAX. Ø OF GRINDING DISC	115 MM
MAX. Ø OF RUBBER SANDING PLATE	115 MM
MAX. Ø OF CIRCULAR WIRE BRUSH	75 MM
MAX. Ø OF CUP WIRE BRUSH	75 MM
WEIGHT	2 KG

ANGLE GRINDER CT13502-125R

- M 14 SPINDLE THREAD
- SOFT START
- SPINDLE LOCK
- RESTART PROTECTION
- TWO-POSITION ON / OFF SWITCH

ACCESSORIES INCLUDED
Flange wrench, Additional handle,
Protective casing.



1010 W

RATED SPEED	11000 MIN ⁻¹
AMPERAGE AT VOLTAGE 220-230 V	4.5 A
MAX. Ø OF CUTTING DISC	125 MM
MAX. Ø OF GRINDING DISC	125 MM
MAX. Ø OF RUBBER SANDING PLATE	125 MM
MAX. Ø OF CIRCULAR WIRE BRUSH	75 MM
MAX. Ø OF CUP WIRE BRUSH	75 MM
WEIGHT	2,05 KG

ANGLE GRINDER CT13506-125V

- M 14 SPINDLE THREAD
- VARIABLE SPEED
- SPINDLE LOCK
- LOCK-OFF FUNCTION
- SOFT GRIP

ACCESSORIES INCLUDED
Flange wrench, Additional handle,
Protective casing.



1200 W

RATED SPEED	0-11000 MIN ⁻¹
AMPERAGE AT VOLTAGE 220-230 V	5.4 A
MAX. Ø OF CUTTING DISC	125 MM
MAX. Ø OF GRINDING DISC	125 MM
MAX. Ø OF RUBBER SANDING PLATE	125 MM
MAX. Ø OF CIRCULAR WIRE BRUSH	75 MM
MAX. Ø OF CUP WIRE BRUSH	75 MM
WEIGHT	2,4 KG

ANGLE GRINDER CT13507-150

- M 14 SPINDLE THREAD
- SPINDLE LOCK
- LOCK-OFF FUNCTION
- SOFT GRIP

ACCESSORIES INCLUDED
Flange wrench, Additional handle,
Protective casing.



1500 W

RATED SPEED	9500 MIN ⁻¹
AMPERAGE AT VOLTAGE 220-230 V	7 A
MAX. Ø OF CUTTING DISC	150 MM
MAX. Ø OF GRINDING DISC	150 MM
MAX. Ø OF RUBBER SANDING PLATE	150 MM
MAX. Ø OF CIRCULAR WIRE BRUSH	75 MM
MAX. Ø OF CUP WIRE BRUSH	75 MM
WEIGHT	3,48 KG

ANGLE GRINDER CT13500-180S

2200 W

- M 14 SPINDLE THREAD
- SPINDLE LOCK
- SOFT START
- LOCK-OFF FUNCTION
- SOFT GRIP

ACCESSORIES INCLUDED
Flange wrench, Additional handle,
Protective casing.



RATED SPEED	8500 MIN ⁻¹
AMPERAGE AT VOLTAGE 220-230 V	10 A
MAX. Ø OF CUTTING DISC	180 MM
MAX. Ø OF GRINDING DISC	180 MM
MAX. Ø OF RUBBER SANDING PLATE	180 MM
MAX. Ø OF CIRCULAR WIRE BRUSH	100 MM
MAX. Ø OF CUP WIRE BRUSH	100 MM
WEIGHT	5,2 KG

ANGLE GRINDER CT13500-230S

2200 W

- M 14 SPINDLE THREAD
- SOFT START
- SPINDLE LOCK
- LOCK-OFF FUNCTION
- SOFT GRIP

ACCESSORIES INCLUDED
Flange wrench, Additional handle,
Protective casing.



RATED SPEED	6500 MIN ⁻¹
AMPERAGE AT VOLTAGE 220-230 V	10 A
MAX. Ø OF CUTTING DISC	230 MM
MAX. Ø OF GRINDING DISC	230 MM
MAX. Ø OF RUBBER SANDING PLATE	230 MM
MAX. Ø OF CIRCULAR WIRE BRUSH	100 MM
MAX. Ø OF CUP WIRE BRUSH	100 MM
WEIGHT	5,4 KG

ANGLE GRINDER CT13500-230S BMC

2200 W

- M 14 SPINDLE THREAD
- SOFT START
- SPINDLE LOCK
- LOCK-OFF FUNCTION
- SOFT GRIP

ACCESSORIES INCLUDED
Flange wrench, Additional handle,
Protective casing.



Rated speed	6500 min ⁻¹
Amperage at voltage 220-230 V	10 A
Max. Ø of cutting disc	230 mm
Max. Ø of grinding disc	230 mm
Max. Ø of rubber sanding plate	230 mm
Max. Ø of circular wire brush	100 mm
Max. Ø of cup wire brush	100 mm
Weight	5,4 kg

ANGLE GRINDER CT13070

2200 W

- M 14 SPINDLE THREAD
- SPINDLE LOCK
- LOCK-ON FUNCTION
- SOFT GRIP

ACCESSORIES INCLUDED
Flange wrench, Additional handle,
Protective casing.



RATED SPEED	6500 MIN ⁻¹
AMPERAGE AT VOLTAGE 220-230 V	10 A
MAX. Ø OF CUTTING DISC	230 MM
MAX. Ø OF GRINDING DISC	230 MM
MAX. Ø OF RUBBER SANDING PLATE	230 MM
MAX. Ø OF CIRCULAR WIRE BRUSH	100 MM
MAX. Ø OF CUP WIRE BRUSH	100 MM
WEIGHT	5,6 KG

ANGLE GRINDER CT13489-230S

2600 W

- M 14 SPINDLE THREAD
- SOFT START
- SPINDLE LOCK
- LOCK-OFF FUNCTION
- SOFT GRIP

ACCESSORIES INCLUDED
Flange wrench, Additional handle,
Protective casing.



RATED SPEED	6500 MIN ⁻¹
AMPERAGE AT VOLTAGE 220-230 V	12 A
MAX. Ø OF CUTTING DISC	230 MM
MAX. Ø OF GRINDING DISC	230 MM

MAX. Ø OF RUBBER SANDING PLATE	230 MM
MAX. Ø OF CIRCULAR WIRE BRUSH	100 MM
MAX. Ø OF CUP WIRE BRUSH	100 MM
WEIGHT	5,9 KG

POLISHER
CT13302

1300 W

- M 14 TOOL HOLDER THREAD
- VELCRO FIXING SYSTEM
- VARIABLE SPEED
- ROTATION SPEED STABILIZATION SYSTEM
- SPINDLE LOCK
- LOCK-ON FUNCTION
- SOFT GRIP

ACCESSORIES INCLUDED
Additional handle, Rubber plate
Polishing bonnet, Wrench.



AMPERAGE AT VOLTAGE 220-230 V	6.5 A
RATED SPEED	1000-3000 MIN ⁻¹
MAX. Ø OF RUBBER PLATE	180 MM
WEIGHT	3,1 KG



POLISHER
CT13528

1500 W

- M 14 SPINDLE THREAD
- VARIABLE SPEED
- SOFT START
- SPINDLE LOCK
- ANTI-VIBRATIONS SYSTEM

ACCESSORIES INCLUDED
Additional handle, Rubber plate
Polishing bonnet, Wrench.



AMPERAGE AT VOLTAGE 220-230 V	6.5 A
RATED SPEED	520-4000 MIN ⁻¹
MAX. Ø OF RUBBER PLATE	180 MM
WEIGHT	2,6 KG

STRAIGHT GRINDER
CT13307

600 W

- VARIABLE SPEED
- TWO-POSITION ON / OFF SWITCH
- SOFT GRIP

ACCESSORIES INCLUDED
Open spanner, Additional handle.



AMPERAGE AT VOLTAGE 220-230 V	2.8 A
NO-LOAD SPEED	12000-27000 MIN ⁻¹
NUMBER OF RPM STAGES	6
SPINDLE INNER DIAMETER	10 MM
COLLET DIAMETER	6 MM
WEIGHT	1,68 KG

STRAIGHT GRINDER
CT13308

600 W

- VARIABLE SPEED
- TWO-POSITION ON / OFF SWITCH

ACCESSORIES INCLUDED
Open spanner, Pin.



AMPERAGE AT VOLTAGE 220-230 V	2.8 A
NO-LOAD SPEED	12000-27000 MIN ⁻¹
NUMBER OF RPM STAGES	6
SPINDLE INNER DIAMETER	10 MM
COLLET DIAMETER	6 MM
WEIGHT	1,46 KG

BURNISHING MACHINE
CT13551-110RSV

1400 W

- VARIABLE SPEED
- ROTATION SPEED STABILIZATION SYSTEM
- SOFT START
- SPINDLE LOCK
- RESTART PROTECTION
- TWO-POSITION ON / OFF SWITCH

ACCESSORIES INCLUDED
Additional handle, Protective casing,
Dowel 2 pcs, Vacuum cleaner adapter,
Allen key.



RATED SPEED	1000-4000 MIN ⁻¹
AMPERAGE AT VOLTAGE 220-230 V	6.6 A
SPINDLE Ø	19 MM
MAX. Ø OF BRUSH	110 MM
MAX. WIDTH OF BRUSH	100 MM
WEIGHT	3,1 KG

BRUSH FOR WOOD, ROUGH FINISHING
CAQ-V11003



DIMENSION	Ø 110 X W 100 X Ø 19 MM
WIRE Ø	0,3 MM
MAX. SPEED	4000 MIN-1
WEIGHT	1,32 KG
SUITABLE FOR	HARD WOOD, AGED WOOD REMOVE PAINT
FINISHING	ROUGH FINISHING



BRUSH FOR METAL AND STAINLESS STEEL, FINE FINISHING
CAQ-S11080



DIMENSION	Ø 110 X W 100 X Ø 19 MM
GRIT	P80
MAX. SPEED	4000 MIN-1
WEIGHT	0,46 KG
SUITABLE FOR	METAL, STAINLESS STEEL
FINISHING	FINE FINISHING



BRUSH FOR WOOD, FINE FINISHING
CAQ-N1101460



DIMENSION	Ø 110 X W 100 X Ø 19 MM
WIRE Ø	1,4 MM
MAX. SPEED	4000 MIN-1
WEIGHT	0,4 KG
SUITABLE FOR	SOFT WOOD, AGED WOOD
FINISHING	FINE FINISHING



LAMELLAR ABRASIVE BRUSH

NEW

- CAQ-P11046**
- CAQ-P11060**
- CAQ-P11080**
- CAQ-P11120**
- CAQ-P11180**



DIMENSION	Ø 110 X W 100 X Ø 19 MM
GRIT	P46 / P60 / P80 / P120 / P180
MAX. SPEED	4000 MIN-1
SUITABLE FOR	METAL, STAINLESS STEEL
FINISHING	FINE FINISHING

BRUSH FOR METAL AND WOOD, FINE FINISHING
CAQ-F11080



DIMENSION	Ø 110 X W 100 X Ø 19 MM
GRIT	P80
MAX. SPEED	4000 MIN-1
WEIGHT	0,5 KG
SUITABLE FOR	METAL, WOOD POLISH
FINISHING	FINE FINISHING



WOOL POLISHING BRUSH
CAQ-L110

NEW



DIMENSION	Ø 110 X W 100 X Ø 19 MM
MATERIAL	WOOL
MAX. SPEED	4000 MIN-1
SUITABLE FOR	METAL, STAINLESS STEEL
FINISHING	POLISHING



HEMP POLISHING BRUSH
CAQ-H110

NEW



DIMENSION	Ø 110 X W 100 X Ø 19 MM
MATERIAL	HEMP
MAX. SPEED	4000 MIN-1
SUITABLE FOR	METAL, STAINLESS STEEL
FINISHING	POLISHING

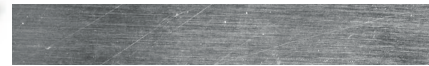

NON-WOVEN POLISHING BRUSH
CAQ-C110

NEW



DIMENSION	Ø 110 X W 100 X Ø 19 MM
MATERIAL	NON-WOVEN
MAX. SPEED	4000 MIN-1
SUITABLE FOR	METAL, STAINLESS STEEL
FINISHING	POLISHING



HARD SPONGE ABRASIVE BRUSH
CAQ-B11060



DIMENSION	Ø 110 X W 100 X Ø 19 MM
GRIT	P60
MAX. SPEED	4000 MIN-1
SUITABLE FOR	MULTI-MATERIAL
FINISHING	FINE FINISHING





BENCH GRINDER
CT13545

170 W

- ADJUSTABLE WORK PIECE SUPPORT
- ADJUSTABLE SPARK PROTECTOR

ACCESSORIES INCLUDED

Mounting screw with nut 2 pcs,
Workpiece support 2 pcs,
Screw with fly-nut 2 pcs,
Spark protector 2 pcs,
Grinding disc 2 pcs,



AMPERAGE AT VOLTAGE 220-230 V	0.7 A
NO-LOAD SPEED	2840 MIN ⁻¹
Ø OF GRINDING DISC	125 / 125 MM
BORE Ø OF GRINDING DISC	12,7 / 32 MM
THICKNESS OF GRINDING DISC	16 / 16 MM
WEIGHT	5 KG

BENCH GRINDER
CT13546

250 W

- ADJUSTABLE WORK PIECE SUPPORT
- ADJUSTABLE SPARK PROTECTOR

ACCESSORIES INCLUDED

Mounting screw with nut 2 pcs,
Workpiece support 2 pcs,
Screw with fly-nut 2 pcs,
Spark protector 2 pcs,
Grinding disc 2 pcs,



AMPERAGE AT VOLTAGE 220-230 V	1.1 A
NO-LOAD SPEED	2840 MIN ⁻¹
Ø OF GRINDING DISC	150 / 150 MM
BORE Ø OF GRINDING DISC	12,7 / 32 MM
THICKNESS OF GRINDING DISC	20 / 20 MM
WEIGHT	7 KG

BENCH GRINDER
CT13547

350 W

- ADJUSTABLE WORK PIECE SUPPORT
- ADJUSTABLE SPARK PROTECTOR

ACCESSORIES INCLUDED

Mounting screw with nut 2 pcs,
Workpiece support 2 pcs,
Screw with fly-nut 2 pcs,
Spark protector 2 pcs,
Grinding disc 2 pcs,



AMPERAGE AT VOLTAGE 220-230 V	1.7 A
NO-LOAD SPEED	2840 MIN ⁻¹
Ø OF GRINDING DISC	200 / 200 MM
BORE Ø OF GRINDING DISC	12,7 / 32 MM
THICKNESS OF GRINDING DISC	20 / 20 MM
WEIGHT	12 KG

CUT-OFF SAW

CT15232

- SPINDLE LOCK
- MITRE ANGULAR ADJUSTMENT
- CARRIAGE POSITION
- LOCK-OFF FUNCTION

ACCESSORIES INCLUDED

Cutting disc.

AMPERAGE AT VOLTAGE 220-230 V	10.6 A
MAX. Ø OF CUTTING DISC	355 MM
NO-LOAD SPEED	3900 MIN ⁻¹
BORE Ø OF CUTTING DISC	25.4 MM
MAX. THICKNESS OF CUTTING DISC	3.5 MM
MAXIMUM SIZE OF CUT-OFF WORKPIECE:	
● WORKPIECE (Ø; CUTTING AT 0° / 45°)	130 / 110 MM
■ WORKPIECE (L × H; CUTTING AT 0° / 45°)	115 X 115 / 90 X 90 MM
■ WORKPIECE (L × H; CUTTING AT 0° / 45°)	205 X 95 / 100 X 85 MM
└ WORKPIECE (L × H; CUTTING AT 0° / 45°)	140 X 140 / 85 X 85 MM
WEIGHT	18,25 KG



2200 W

JIGSAW

CT15212

- STROKE RATE REGULATION
- 4-STAGE PENDULUM
- ANGULAR ADJUSTMENT
- SAW BLADE EASY CHANGE
- LOCK-ON FUNCTION
- DUST EXTRACTION SYSTEM

ACCESSORIES INCLUDED

Saw blade, Wing screw for guide bar, Locating pin, Allen key, Vacuuming connector piece.



550 W

AMPERAGE AT VOLTAGE 220-230 V	2.4 A
STROKE RATE AT NO-LOAD	700-3000 MIN ⁻¹
STROKE LENGTH	18 MM
CUTTING ABILITY IN WOOD	65 MM
CUTTING ABILITY IN ALUMINUM	10 MM
CUTTING ABILITY IN STEEL	6 MM
MAX. ANGULARITY OF THE BODY (LEFT / RIGHT)	45°/45°
WEIGHT	1,9 KG

JIGSAW

CT15181

- STROKE RATE REGULATION
- 4-STAGE PENDULUM
- ANGULAR ADJUSTMENT
- SAW BLADE EASY CHANGE
- TWO-POSITION ON / OFF SWITCH
- DUST BLOWING
- DUST EXTRACTION SYSTEM
- ERGONOMIC HANDLE

ACCESSORIES INCLUDED

Allen key, Saw blade, Locating pin, Parallel guide, Vacuuming connector piece.

AMPERAGE AT VOLTAGE 220-230 V	3.1 A
STROKE RATE AT NO-LOAD	700-3000 MIN ⁻¹
STROKE LENGTH	26 MM
CUTTING ABILITY IN WOOD	120 MM
CUTTING ABILITY IN ALUMINUM	20 MM
CUTTING ABILITY IN STEEL	10 MM
MAX. ANGULARITY OF THE BODY (LEFT / RIGHT)	45° / 45°
WEIGHT	3 KG

JIGSAW

CT15189

- STROKE RATE REGULATION
- 4-STAGE PENDULUM
- ANGULAR ADJUSTMENT
- SAW BLADE EASY CHANGE
- LOCK-ON FUNCTION
- DUST EXTRACTION SYSTEM
- SOFT GRIP

ACCESSORIES INCLUDED

Saw blade, Wing screw for guide bar, Locating pin, Allen key, Vacuuming connector piece, Guide bar for parallel / circle cutting.



710 W

AMPERAGE AT VOLTAGE 220-230 V	3.1 A
STROKE RATE AT NO-LOAD	700-3000 MIN ⁻¹
STROKE LENGTH	26 MM
CUTTING ABILITY IN WOOD	125 MM
CUTTING ABILITY IN ALUMINUM	20 MM
CUTTING ABILITY IN STEEL	10 MM
MAX. ANGULARITY OF THE BODY (LEFT / RIGHT)	45°/45°
WEIGHT	2,9 KG



710 W

SABRE SAW

CT15133

- STROKE RATE REGULATION
- ELECTRONIC SPEED ADJUSTMENT
- SAW BLADE EASY CHANGE
- LOCK-ON FUNCTION
- REAR D-HANDLE
- SOFT GRIP

ACCESSORIES INCLUDED

Saw blade.



AMPERAGE AT VOLTAGE 220-230 V	4,5 A
STROKE RATE AT NO-LOAD	300-2400 MIN ⁻¹
STROKE LENGTH	28 MM
CUTTING ABILITY IN WOOD	250 MM
CUTTING ABILITY IN STEEL (PROFILE / PIPE)	8 / 120 MM
WEIGHT	3,7 KG

1010 W



CIRCULAR SAW

CT15187-165

- SPINDLE LOCK
- CUTTING DEPTH ADJUSTMENT
- ANGULAR ADJUSTMENT
- LOCK-OFF FUNCTION
- DUST EXTRACTION SYSTEM
- SOFT GRIP

ACCESSORIES INCLUDED

Circular saw blade, Wrench, Parallel guide.



1200 W

AMPERAGE AT VOLTAGE 220-230 V	5,6 A
NO-LOAD SPEED	5500 MIN ⁻¹
MIN. / MAX. Ø OF CIRCULAR SAW BLADE	160 / 166 MM
BORE Ø OF CIRCULAR SAW BLADE	20 MM
MAX. THICKNESS OF CIRCULAR SAW BLADE	2 MM
MAX. CUTTING DEPTH BY 90°	54 MM
MAX. CUTTING DEPTH BY 45°	38 MM
WEIGHT	3,9 KG

CIRCULAR SAW

CT15188-190

- SPINDLE LOCK
- CUTTING DEPTH ADJUSTMENT
- ANGULAR ADJUSTMENT
- LOCK-OFF FUNCTION
- DUST EXTRACTION SYSTEM
- SOFT GRIP

ACCESSORIES INCLUDED

Circular saw blade, Wrench, Parallel guide.



1500 W

AMPERAGE AT VOLTAGE 220-230 V	6,8 A
NO-LOAD SPEED	5500 MIN ⁻¹
MIN. / MAX. Ø OF CIRCULAR SAW BLADE	185 / 190 MM
BORE Ø OF CIRCULAR SAW BLADE	20 MM
MAX. THICKNESS OF CIRCULAR SAW BLADE	2 MM
MAX. CUTTING DEPTH BY 90°	66 MM
MAX. CUTTING DEPTH BY 45°	46 MM
WEIGHT	4,4 KG

CIRCULAR SAW

CT15210-235

- SPINDLE LOCK
- CUTTING DEPTH ADJUSTMENT
- ANGULAR ADJUSTMENT
- LOCK-OFF FUNCTION
- DUST EXTRACTION SYSTEM
- SOFT GRIP

ACCESSORIES INCLUDED

Circular saw blade, Wrench, Parallel guide.



2000 W

AMPERAGE AT VOLTAGE 220-230 V	10 A
NO-LOAD SPEED	4500 MIN ⁻¹
MIN. / MAX. Ø OF CIRCULAR SAW BLADE	230 / 235 MM
BORE Ø OF CIRCULAR SAW BLADE	30 MM
MAX. THICKNESS OF CIRCULAR SAW BLADE	2,4 MM
MAX. CUTTING DEPTH BY 90°	85 MM
MAX. CUTTING DEPTH BY 45°	60 MM
WEIGHT	7,6 KG

PLUNGE SAW
CT15134-165

1300 W

- VARIABLE SPEED
- ROTATION SPEED STABILIZATION SYSTEM
- SOFT START
- OVERLOAD PROTECTION
- CUTTING DEPTH ADJUSTMENT
- ANGULAR ADJUSTMENT
- SAFETY LOCK

ACCESSORIES INCLUDED
 Circular saw blade, Allen key, Parallel guide.

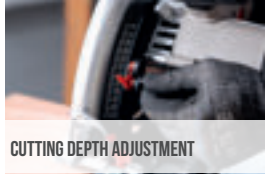

CUTTING DEPTH ADJUSTMENT



VARIABLE SPEED



AMPERAGE AT VOLTAGE 220-230 V	6.2 A
NO-LOAD SPEED	2000-5000 MIN ⁻¹
CIRCULAR SAW BLADE Ø	165 MM
CIRCULAR SAW BLADE BORE Ø	20 MM
MAX. THICKNESS OF CIRCULAR SAW BLADE	2,4 MM
MAX. CUTTING DEPTH BY 90°	55 MM
MAX. CUTTING DEPTH BY 45°	38 MM
WEIGHT	4,7 KG

PLUNGE SAW GUIDE
CAXS-BA 140

- COMPATIBLE WITH: CT15134-165
- EQUIPPED WITH CONNECTION KIT, TO JOIN A SECOND GUIDE TOGETHER.



L 140,5 x W 22 x H 2 cm

WEIGHT	2,1 KG
--------	--------



SLIDE MITRE SAW CT15233P

1800 W

- SPINDLE LOCK
- ANGULAR ADJUSTMENT
- MITRE ANGULAR ADJUSTMENT
- CLAMPING DEVICE
- BOTH-SIDED TABLE EXTENSIONS
- KERF LASER INDICATOR
- INTEGRATED LED LIGHT
- CARRIAGE POSITION

ACCESSORIES INCLUDED

Saw blade, Extension bracket, Clamping screw, Dust bag, Allen key.

AMPERAGE AT VOLTAGE 220-230 V	8.7 A
NO-LOAD SPEED	5500 MIN ⁻¹
CIRCULAR SAW BLADE Ø	255 MM
MIN. / MAX. BORE Ø OF SAW BLADE	16 (OPTIONAL EXTRA) / 30 MM
MAX. THICKNESS OF CIRCULAR SAW BLADE	2,8 MM
MAX. CUTTING DEPTH AT 0° / 90° (H X W)	80 X 340 MM
MAX. CUTTING DEPTH AT 45° / 90° (H X W)	80 X 240 MM
MAX. CUTTING DEPTH AT 0° / 45° (H X W)	50 X 340 MM
MAX. CUTTING DEPTH AT 45° / 45° (H X W)	50 X 240 MM
WEIGHT	16,5 KG



COMBO MITRE SAW CT15305KF

1700 W

NEW

- 3 MODES HANDLE POSITION
- SPINDLE LOCK
- ANGULAR ADJUSTMENT
- MITRE ANGULAR ADJUSTMENT
- CLAMPING DEVICE

ACCESSORIES INCLUDED

Saw blade, Clamping screw, Dust bag, Allen key.

AMPERAGE AT VOLTAGE 220-230 V	7.7 A
NO-LOAD SPEED	4200 MIN ⁻¹
CIRCULAR SAW BLADE Ø	305 MM
CIRCULAR SAW BLADE BORE Ø	30 MM
MAX. CUTTING DEPTH AT 0° / 90° (H X W)	100 X 165 MM
MAX. CUTTING DEPTH AT 45° / 90° (H X W)	100 X 105 MM
MAX. CUTTING DEPTH AT 0° / 45° (H X W)	65 X 165 MM
MAX. CUTTING DEPTH AT 45° / 45° (H X W)	70 X 45 MM
WEIGHT	18 KG



TABLE SAW CT15286S

3000 W

NEW

- CUTTING DEPTH ADJUSTMENT
- ANGULAR ADJUSTMENT
- MITRE ANGULAR ADJUSTMENT
- OVERLOAD PROTECTION
- SLIDING WORKING TABLE
- DUST EXTRACTION SYSTEM

ACCESSORIES INCLUDED

Dust extraction pipe, Movable protection cover, Saw blade, Angular stop, Parallel guide, Push stick, Wrench 2 pcs.

AMPERAGE AT VOLTAGE 220-240 V	13 A
NO-LOAD SPEED	5000 MIN ⁻¹
RATED POWER	500 W
NO-LOAD SPEED	16000 MIN ⁻¹
CIRCULAR SAW BLADE Ø	254 MM
CIRCULAR SAW BLADE BORE Ø	25,4 MM
MAX. THICKNESS OF CIRCULAR SAW BLADE	2,8 MM
MAX. CUTTING DEPTH AT 90°	86 MM
MAX. CUTTING DEPTH AT 45°	60 MM
WEIGHT	34 KG



ROTARY SANDER

CT13394

- VELCRO FIXING SYSTEM
- DUST EXTRACTION SYSTEM
- SOFT GRIP

ACCESSORIES INCLUDED
Sanding paper, Dust bag.



AMPERAGE AT VOLTAGE 220-230 V	1 A
NO-LOAD SPEED	12000 MIN ⁻¹
NO-LOAD OSCILLATIONS RATE	24000 MIN ⁻¹
ECCENTRICITY	2 MM
SANDING PLATE DIAMETER	125 MM
WEIGHT	1,5 KG

240 W

ROTARY SANDER

CT13560V

- VELCRO FIXING SYSTEM
- VARIABLE SPEED
- DUST EXTRACTION SYSTEM
- SOFT GRIP

ACCESSORIES INCLUDED
Sanding paper,
Dust-collecting container.



AMPERAGE AT VOLTAGE 220-230 V	1.4 A
NO-LOAD SPEED (GEAR I / II)	6000-13000 MIN ⁻¹
NO-LOAD OSCILLATIONS RATE	12000-26000 MIN ⁻¹
ECCENTRICITY	2 MM
SANDING PLATE DIAMETER	125 MM
WEIGHT	1,5 KG

300 W

ROTARY SANDER

CT13395

- VELCRO FIXING SYSTEM
- VARIABLE SPEED
- LOCK-ON FUNCTION
- DUST EXTRACTION SYSTEM
- REAR D-HANDLE
- SOFT GRIP

ACCESSORIES INCLUDED
Sanding paper, Dust bag.



AMPERAGE AT VOLTAGE 220-230 V	1.9 A
NO-LOAD SPEED (GEAR I / II)	4000-13000 MIN ⁻¹
NO-LOAD OSCILLATIONS RATE	8000-26000 MIN ⁻¹
ECCENTRICITY	2 MM
SANDING PLATE DIAMETER	150 MM
WEIGHT	2,4 KG

450 W

ORBITAL SANDER

CT13637

- VELCRO FIXING SYSTEM
- DUST EXTRACTION SYSTEM
- SOFT GRIP

ACCESSORIES INCLUDED
Sanding paper, Dust bag.



NO-LOAD SPEED	13000 MIN ⁻¹
NO-LOAD OSCILLATION RATE	26000 MIN ⁻¹
ORBITAL DIAMETER	1,6 MM
SANDING SURFACE SIZE	140 X 140 X 80 MM
SANDING PAPER SIZE (CLAMP / VELCRO)	140 X 140 X 80 MM
WEIGHT	1,3 KG

180 W

NEW

ORBITAL SANDER

CT13638

- VELCRO FIXING SYSTEM
- DUST EXTRACTION SYSTEM
- SOFT GRIP

ACCESSORIES INCLUDED
Sanding paper, Dust bag.

ACCESSORIES INCLUDED
Sanding paper, Dust bag.



NO-LOAD SPEED	13000 MIN ⁻¹
NO-LOAD OSCILLATION RATE	26000 MIN ⁻¹
ORBITAL DIAMETER	1,6 MM

SANDING SURFACE SIZE	110 X 100 MM
SANDING PAPER SIZE (CLAMP / VELCRO)	115 X 140 MM / 114 X 109 MM
WEIGHT	1,4 KG

240 W

NEW

ORBITAL SANDER CT13633V

- VELCRO AND CLAMPING FIXING SYSTEM
- VARIABLE SPEED
- LOCK-ON FUNCTION
- DUST EXTRACTION SYSTEM
- SOFT GRIP

ACCESSORIES INCLUDED
Sanding paper, Dust bag.



380 W

NEW

NO-LOAD SPEED	7000-13000 MIN ⁻¹
NO-LOAD OSCILLATION	14000-26000 MIN ⁻¹
ORBITAL DIAMETER	1 MM

SANDING SURFACE SIZE	115 X 230 MM
SANDING PAPER SIZE (CLAMP / VELCRO)	115 X 280 MM / 115 X 230 MM
WEIGHT	2,2 KG



POWER PLANER CT14019X

710 W

- INTERCHANGEABLE BLADES
- PLANING DEPTH REGULATOR
- V-GROOVE
- REBATING
- SAFETY STOP
- LOCK-OFF FUNCTION
- SOFT GRIP

ACCESSORIES INCLUDED
Vertical stop, Box wrench,
Side stop,
Wing screw for guide bar.



AMPERAGE AT VOLTAGE 220-230 V	3.3 A
NO-LOAD SPEED	16000 MIN ⁻¹
PLANING WIDTH	82 MM
PLANING DEPTH	0-2,5 MM
GROOVING DEPTH	0-15 MM
WEIGHT	2,8 KG

MULTI-FUNCTION TOOL CT16008 BMC

- SPECIAL ACCESSORIES CONNECTION
- VELCRO AND CLAMPING FIXING SYSTEM
- VARIABLE SPEED
- SOFT START
- SOFT GRIP

ACCESSORIES INCLUDED

Additional handle, Vacuum cleaner adapter,
Plunge cutting saw blade, Scraper, Segment saw blade,
Sanding plate (velcro type), Sanding sheet (velcro type)



500 W

NEW

AMPERAGE AT VOLTAGE 220-230 V	2.1 A
NO-LOAD SPEED	8000-16000 MIN ⁻¹

OSCILLATION ANGLE LEFT/RIGHT	5°
WEIGHT	1,42 KG

EDGE TRIMMER

CT11023S

- VARIABLE SPEED
- SOFT START
- ROTATION SPEED STABILIZATION SYSTEM
- SPINDLE LOCK
- PLUNGE DEPTH CONTROL SYSTEM
- DUST EXTRACTION SYSTEM
- SOFT GRIP

ACCESSORIES INCLUDED

Trimmer bases 3pcs, Setcrews 2 pcs, Movable holder for parallel guide, Parallel guide, Roller guide, Dust extractor connecting adaptor, Collet Ø6, Collet Ø8, Wrench.



710 W

AMPERAGE AT VOLTAGE 220-230 V	3,4 A
NO-LOAD SPEED	13000-33000 MIN ⁻¹
COLLET INNER Ø	6-8 MM
STROKE OF THE ROUTER BASE	20 MM
WEIGHT	1,45 KG

EDGE TRIMMER

CT11020

- SPINDLE LOCK
- PLUNGE DEPTH CONTROL SYSTEM
- LOCK-ON FUNCTION
- DUST EXTRACTION SYSTEM

ACCESSORIES INCLUDED

Router bit, Parallel guide, Dust extractor connecting adaptor, Wrench.



430 W

AMPERAGE AT VOLTAGE 220-230 V	2,1 A
NO-LOAD SPEED	26000 MIN ⁻¹
COLLET INNER Ø	6 MM
STROKE OF THE ROUTER BASE	30 MM
WEIGHT	1,5 KG



PLUNGE ROUTER

CT11001

- VARIABLE SPEED
- SOFT START
- ROTATION SPEED STABILIZATION SYSTEM
- SPEED ADJUSTMENT
- SPINDLE LOCK
- PLUNGE DEPTH CONTROL SYSTEM
- LOCK-ON FUNCTION
- DUST EXTRACTION SYSTEM

ACCESSORIES INCLUDED

Bush, Guide bushing, Guide bushing fixing screws 3pcs, Parallel guide, Dust extractor connecting adaptor, Wrench.



2100 W

AMPERAGE AT VOLTAGE 220-230 V	9 A
NO-LOAD SPEED	8000-23000 MIN ⁻¹
COLLET INNER Ø	12 MM
STROKE OF THE ROUTER BASE	60 MM
WEIGHT	6,3 KG

BISQUIT JOINTER

CT13587

- M10 SPINDLE THREAD
- SPINDLE LOCK
- LOCK-ON FUNCTION
- SOFT GRIP

ACCESSORIES INCLUDED

Dust extraction pipe, Flange wrench, Adapter.



860 W

NO-LOAD SPEED	11000 MIN ⁻¹
AMPERAGE AT VOLTAGE 220-230 V	3.8 A
MAX / MIN. Ø OF CIRCULAR SAW BLADE	100 MM
BORE Ø OF CIRCULAR SAW BLADE	22 MM

MAX. THICKNESS OF CIRCULAR SAW BLADE	3.8 MM
MAX. MILLING DEPTH	15 MM
WEIGHT	3,1 KG

BISQUITS FOR BISQUIT JOINTER

CCB-0X50



SIZE	0
DIMENSION	16 X 48 MM

CCB-10X50



SIZE	10
DIMENSION	21 X 54 MM

CCB-20X50



SIZE	20
DIMENSION	24 X 57 MM



AIR BLOWER

CT17010V-A

- VARIABLE SPEED
- 2 FUNCTION MODES (BLOWER / VACUUM CLEANER)
- POSSIBILITY OF STEADY-STATE USE
- LOCK-ON FUNCTION

ACCESSORIES INCLUDED

Dust collector, Crevice nozzle, Hose.



710 W

AMPERAGE AT VOLTAGE 220-230 V	3.08 A
NO-LOAD SPEED	0-14000 MIN ⁻¹

AIR FLOW RATE	0-4 M ³ /MIN
WEIGHT	1,6 KG

HOT AIR GUN
CT19022K

100 / 800 / 1800 W

- 3-STEP REGULATOR
- COOL STAGE
- TEMPERATURE PROTECTION
- POSSIBILITY OF STEADY-STATE USE

ACCESSORIES INCLUDED

Scraper, Flat nozzle, Deflector nozzle, Reflector nozzle, Point nozzle.



AMPERAGE AT VOLTAGE 220-230 V	7,8 A
TEMPERATURE (STAGE I / II / III)	50 / 450 / 550 °C
AIR FLOW (STAGE I / II / III)	250 / 250 / 500 L/MIN
WEIGHT	0,7 KG

HOT AIR GUN
CT19023K

60 / 60-2000 / 120-2000 W

- 3-STEP REGULATOR
- COOL STAGE
- TEMPERATURE SETTING
- TEMPERATURE PROTECTION
- POSSIBILITY OF STEADY-STATE USE
- SOFT GRIP

ACCESSORIES INCLUDED

Scraper, Flat nozzle, Deflector nozzle, Reflector nozzle, Point nozzle.



AMPERAGE AT VOLTAGE 220-230 V	8,7 A
TEMPERATURE (STAGE I / II / III)	50 / 50-600 / 50-600 °C
AIR FLOW (STAGE I / II / III)	250 / 250 / 500 L/MIN
WEIGHT	0,9 KG

SPRAY GUN
CT31013

400 W

- VARIABLE PAINT FLOW
- ADJUSTABLE NOZZLE
- EASY FILL
- SAFETY CLEANING
- SOFT GRIP

ACCESSORIES INCLUDED

Nozzles 2 pcs, Measuring funnel, Cleaning rod, Cleaning brush, Seal ring 2 pcs, Special wrench for nozzles.



AMPERAGE AT VOLTAGE 220-230 V	1,5 A
FLOW RATE	800 ML/MIN
MAX. SPRAYING PRESSURE	0,1 - 0,2 BAR
MAX. VISCOSITY	70 DIN-S
NOZZLE Ø	2/2,5/3 MM
RESERVOIR CAPACITY	900 ML
WEIGHT	1,5 KG



SPRAY GUN
CT31014

600 W

- VARIABLE PAINT FLOW
- ADJUSTABLE NOZZLE
- EASY FILL
- SAFETY CLEANING
- BUILT-IN STATION
- SOFT GRIP

ACCESSORIES INCLUDED

Air hose, Hose holder 2 pcs, Measuring funnel, Cleaning rod, Cleaning brush, Special wrench for nozzles, Carrying belt.



AMPERAGE AT VOLTAGE 220-230 V	2,5 A
FLOW RATE	1000 ML/MIN
MAX. SPRAYING PRESSURE	0,1 - 0,3 BAR
MAX. VISCOSITY	100 DIN-S
NOZZLE Ø	2,5 MM
RESERVOIR CAPACITY	900 ML
WEIGHT	2,9 KG

ALL-PURPOSE VACUUM CLEANER CT99742

- WET/DRY FUNCTION
- AUTOMATIC ENGINE START
- POSSIBILITY TO CONNECT OTHER POWER TOOLS
- CARTRIDGE FILTER
- 5 M CABLE
- 360° ROTATING WHEELS

ACCESSORIES INCLUDED

Extension tubes 2 pcs, 3 mt tube multidiameter with Ø36/37 adapter, Adapter Ø32/36, Crevice nozzle, Multipurpose brush, Anti foam filter, Paper cartridge filter, Fiber dust bag IFA class M. 2 pcs.



MADE IN ITALY

AIR FLOW RATE	60 L/S
VACUITY	21 KPA
CAPACITY	35 L
WEIGHT	7 KG

1000 W



ALL-PURPOSE VACUUM CLEANER CT99740

- WET/DRY FUNCTION
- AUTOMATIC ENGINE START
- POSSIBILITY TO CONNECT OTHER POWER TOOLS
- SELF CLEANING FILTER
- M DUST CLASS
- 7 M CABLE
- 360° ROTATING METAL WHEELS

ACCESSORIES INCLUDED

Extension tubes 2 pcs, 3 mt tube multidiameter with Ø32/36 adapter, Adapter Ø32/38, Multipurpose brush, Crevice nozzle, Anti foam filter, Polyester cartridge filter IFA class M, Fiber dust bag IFA class M. 2 pcs.



MADE IN ITALY

VACUITY	24 KPA
AIR FLOW RATE	60 L/S
CAPACITY	35 L
WEIGHT	8,5 KG

1200 W

ALL-PURPOSE VACUUM CLEANER CT99741

- WET/DRY FUNCTION
- AUTOMATIC ENGINE START
- POSSIBILITY TO CONNECT OTHER POWER TOOLS
- FULL AUTOMATIC CLEANING FILTER
- M DUST CLASS
- 7 M CABLE
- 360° ROTATING WHEELS

ACCESSORIES INCLUDED

Extension tubes 2 pcs, 3 mt tube multidiameter with Ø32/36 adapter, Adapter Ø32/38, Multipurpose brush, Crevice nozzle, Hard floor insert, Insert for liquid collection, Anti foam filter, Polyester cartridge filter IFA class M, Fiber dust bag IFA class M 2 pcs.



MADE IN ITALY

VACUITY	24 KPA
AIR FLOW RATE	60 L/S
CAPACITY	35 L
WEIGHT	8,5 KG

1200 W

POLYESTER CARTRIDGE FILTER 83208BJA

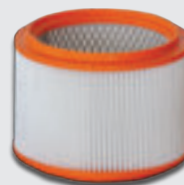

M CLASS
4300 CM²
IFA CERTIFIED

COMPATIBILITY:
CT99740
CT99741

PAPER CARTRIDGE FILTER 83207BJA

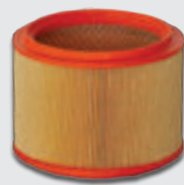

M CLASS
4300 CM²

COMPATIBILITY:
CT99742

ANTI FOAM FILTER 83036BHB



COMPATIBILITY:
CT99740
CT99741
CT99742

FIBER DUST BAG 83148BOK



5 PCS
30-50 L
IFA CERTIFIED

COMPATIBILITY:
CT99740, CT99741
CT99742

LASER MEASURE
CT44028

0,05 m - 40 m

- LASER CLASS 2
- UNITS SELECTION
- TYPE OF MEASURE
- REFERENCE POINT
- CALCULATING
- MEMORY
- BUILT-IN LEVEL
- LCD SCREEN

ACCESSORIES INCLUDED
Batteries 2 pcs.



MEASURING ACCURACY	±2 MM
TIME OF SINGLE MEASUREMENT	0,25 S
LASER TYPE	650 NM
LASER CLASS	II, <1 MW
OPERATING TEMPERATURE RANGE	0 ... +40 °C
STORAGE TEMPERATURE RANGE	-20 ... +65 °C
BATTERY TYPE	2 X 1,5V AAA
WEIGHT	0,089 KG



LASER MEASURE
CT44034

0,05 m - 80 m

- LASER CLASS 2
- UNITS SELECTION
- TYPE OF MEASURE
- REFERENCE POINT
- CALCULATING
- MEMORY
- LEVEL SENSOR
- LCD SCREEN

ACCESSORIES INCLUDED
Batteries 2 pcs, Hand strap.



MEASURING ACCURACY	±2 MM
TIME OF SINGLE MEASUREMENT	0,25 S
LASER TYPE	650 NM
LASER CLASS	II, <1 MW
OPERATING TEMPERATURE RANGE	0 ... +40 °C
STORAGE TEMPERATURE RANGE	-20 ... +65 °C
BATTERY TYPE	2 X 1,5V AAA
WEIGHT	0,107 KG

THERMO DETECTOR
CT44037

-50 °C ~ +600 °C

- LASER CLASS 2
- UNITS SELECTION
- BACKLIGHT
- LCD SCREEN

ACCESSORIES INCLUDED
Batteries 2 pcs.



MEASURING ACCURACY	±2 MM
TIME OF SINGLE MEASUREMENT	0,25 S
LASER TYPE	650 NM
LASER CLASS	II, <1 MW
OPERATING TEMPERATURE RANGE	0 ... +40 °C
STORAGE TEMPERATURE RANGE	-20 ... +65 °C
BATTERY TYPE	2 X 1,5V AAA
WEIGHT	0,089 KG



LINE LASER CT44088-R TB

- GREEN LASER
- HIGH CLASS OSRAM DIODE
- 3 PLANES PROJECTION MODE
- REMOTE CONTROL
- AUTOMATIC SELF-LEVELLING
- UNLEVELLED SIGNAL
- LASER HEAD LOCKING

ACCESSORIES INCLUDED

Laser target plate, USB cable,
Magnetic holder, Carrying bag.

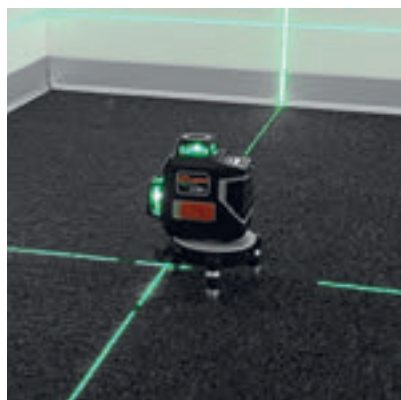

PROJECTED BEAMS	2V(360°), 1H(360°)
LEVELLING ACCURACY - VERTICAL / HORIZONTAL BEAM	±3 MM AT 10 M
SELF-LEVELLING TIME	≤4 S
SELF-LEVELLING RANGE	±4°
LASER CLASS	II
BATTERY TYPE	3,7 V; LI-ION 4AH
THREAD FOR TRIPOD	1/4"
OPERATING TEMPERATURE RANGE	-10 ... +50 °C
STORAGE TEMPERATURE RANGE	-25 ... +70 °C
WEIGHT	1,12 KG

30 m

NEW



LINE LASER CT44047

- GREEN LASER
- HIGH CLASS OSRAM DIODE
- LASER CLASS 2
- 2 LINES PROJECTION MODE
- AUTOMATIC SELF-LEVELLING
- UNLEVELLED SIGNAL
- LASER HEAD LOCKING
- SMART BUTTON

ACCESSORIES INCLUDED

Spring clamp with swivel holder,
Storage bag, Carrying bag.



PROJECTED BEAMS	1V, 1H
LASER WAVELENGTH	520 NM
LEVELLING ACCURACY	±3 MM/10 M
SELF-LEVELLING RANGE	±4°
BATTERY TYPE	4X AA
OPERATION TEMPERATURE	-10°C-40°C
THREAD FOR TRIPOD	1/4"
WEIGHT	0,26 KG

30 m

TELESCOPIC POLE CAXL-S31

NEW



MAX. HEIGHT	3,1 M
PIPE DIAMETER	34 MM
THREAD Ø	5/8"
WEIGHT	1,4 KG

TRIPOD FOR LINE LASERS CAXL-S12

COMPATIBLE WITH:

CT44047
CT44088-R TB

ACCESSORIES INCLUDED

1/4" adapter.



MAX. HEIGHT	120 CM
HEIGHT	76,5 CM
THREAD Ø	5/8"
WEIGHT	0,841 KG

5/8"

TRIPOD FOR OPTICAL LEVEL CAXO-S16

5/8"



MAX. HEIGHT	160 CM
HEIGHT	76,5 CM
THREAD Ø	5/8"
WEIGHT	2,24 KG

DIGITAL CLAMP METER CT44053

- AC/DC VOLTAGE
- AC CURRENT
- RESISTANCE
- DIODE TEST
- NCV TEST
- CONTINUITY TEST
- TORCH LIGHT
- MAX VALUE



600 V
NEW

VOLTAGE AC: MAX VOLT	600 V
VOLTAGE AC: MAX RESOLUTION	1 mV
VOLTAGE DC: MAX VOLT	600 V
VOLTAGE DC: MAX RESOLUTION	0,1 mV
CURRENT AC: MAX AMPS	600 A
CURRENT AC: MAX RESOLUTION	1 mA
RESISTANCE: MAX RESISTANCE	20 MΩ
RESISTANCE: MAX RESOLUTION	0,1 Ω
PLIERS OPENING	25 mm
PESO	0,16 kg

VOLTAGE DETECTOR CT44092

- VIBRATION FUNCTION
- AUDIBLE INDICATOR
- DUAL VOLTAGE MODE
- TORCH LIGHT

1000 V
NEW



AC VOLTAGE RANGE	24 V / 1000 V
FREQUENCY RANGE	50/60 HZ
ALARM MODE	AUDIO/VISUAL/VIBRATION
AUTO POWER OFF	5 MIN
IP RATING	IP67
OPERATING TEMPERATURE RANGE	0 ... +40 °C
STORAGE TEMPERATURE RANGE	-20... +50 °C
HUMIDITY WORKING RANGE	≤80% (NON-CONDENSING)
BATTERY TYPE	2 X 1,5V AAA
WEIGHT	0,072 kg

HIGH-PRESSURE WASHER CT42020

- ADJUSTABLE STREAM
- TEMPERATURE PROTECTION
- PRESSURE PROTECTION

ACCESSORIES INCLUDED

Pressure hose, Spray gun, Jet pipe, Extension tube, Filter.



1400 W

AMPERAGE AT VOLTAGE 220-230 V	4,71 A
VOLTAGE / FREQUENCY	220-230 V / 50-60 HZ
MAX. FEED PRESSURE	0,7 MPA
MAX. FEED TEMPERATURE	<60 °C
MIN. FEED FLOW RATE	5,5 L/MIN
RATED PRESSURE	7 MPA
MAX. PRESSURE	10 MPA
FLOW RATE	5,5 L/MIN
MAX. FLOW RATE	6,5 L/MIN
WEIGHT	5,3 kg

DIGITAL MULTIMETER CT44051

- AC/DC VOLTAGE
- DC CURRENT
- RESISTANCE
- DIODE TEST
- NCV TEST
- TRANSISTOR TEST
- CONTINUITY TEST
- TORCH LIGHT

ACCESSORIES INCLUDED
Test leads



600 V
NEW

VOLTAGE AC: MAX VOLT	600 V
VOLTAGE AC: MAX RESOLUTION	1000 mV
VOLTAGE DC: MAX VOLT	600 V
VOLTAGE DC: MAX RESOLUTION	0,1 mV
CURRENT DC: MAX AMPS	10 A
CURRENT DC: MAX RESOLUTION	1 μA
RESISTANCE: MAX RESISTANCE	20 MΩ
RESISTANCE: MAX RESOLUTION	0,1 Ω
WEIGHT	0,22 kg
PESO	0,22 kg

HIGH-PRESSURE WASHER CT42022

- ADJUSTABLE STREAM
- DETERGENT TANK
- HOSE REEL
- TEMPERATURE PROTECTION
- PRESSURE PROTECTION

ACCESSORIES INCLUDED

Pressure hose, Spray gun, Jet pipe, Filter.



1800 W

AMPERAGE AT VOLTAGE 220-230 V	7,63 A
VOLTAGE / FREQUENCY	220-230 V / 50-60 HZ
MAX. FEED PRESSURE	0,7 MPA
MAX. FEED TEMPERATURE	<60 °C
MIN. FEED FLOW RATE	6,7 L/MIN
RATED PRESSURE	10 MPA
MAX. PRESSURE	14 MPA
FLOW RATE	6,7 L/MIN
MAX. FLOW RATE	7,8 L/MIN
WEIGHT	9,6 kg

HIGH-PRESSURE WASHER CT42024

- ADJUSTABLE STREAM
- ADJUSTING DETERGENT QUANTITY
- DETERGENT TANK
- HOSE REEL
- TEMPERATURE PROTECTION
- PRESSURE PROTECTION

ACCESSORIES INCLUDED

Pressure hose, Spray gun, Jet pipe, Filter.



AMPERAGE AT VOLTAGE 220-230 V	8,32 A
VOLTAGE / FREQUENCY	220-230 V / 50-60 HZ
MAX. FEED PRESSURE	0,7 MPA
MAX. FEED TEMPERATURE	<60 °C
MIN. FEED FLOW RATE	6,78 L/MIN
RATED PRESSURE	11 MPA
MAX. PRESSURE	15 MPA
FLOW RATE	6,7 L/MIN
MAX. FLOW RATE	7,8 L/MIN
WEIGHT	13 KG

2000 W

WELDING MASK CAXW-MA 1

- SENSITIVITY ADJUSTMENT: STEPLESS CONTROL
- DARK STATE SHIFT: STEPLESS SHIFT

Li-Ion battery & solar supply



FILTER SIZE	110 × 90 × 9 MM
LIGHT SHADE	DIN4
DARK SHADE	DIN9~DIN13
SWITCHING TIME	≤ 3 / 10000 S
DELAY TIME	0,1 S ~ 0,8 S
POWER SUPPLY	3,7 V LI-ION
RATED CAPACITY OF LITHIUM BATTERY	600 MAH
OPERATING TEMPERATURE RANGE	-20 C° ~ +65 C°
PROTECT GRADE AGAINST UVB	DIN16

INVERTER DC MMA WELDING MACHINE

CT33102 IMC

- MMA WELDING TECHNOLOGY
- IGBT TECHNOLOGY
- TEMPERATURE PROTECTION
- VOLTAGE REDUCTION DEVICE VRD
- CURRENT CONTROL
- EASY START
- WELDING CURRENT METER

ACCESSORIES INCLUDED

Earth clamp, Earth wire, Electrode holder, Welding mask, Chipping hammer / wire brush, Gloves, Carrying belt.



30-150 A

Rated input voltage	180-265 V
Rated frequency	50/60 HZ
Rated input capacity	6,6 KVA
Rated output voltage	21,2-26 V
No-Load voltage	80 V

Welding electrode diameter	2,5-3,2 MM
Rated duty circle	35%
Efficiency	83%
Weight	3,6 KG

SUBMERSIBLE PUMP CT35047

- ENGINE PROTECTION
- AUTOMATIC ON/OFF SWITCH

ACCESSORIES INCLUDED

Universal fitting.



1200 W

AMPERAGE AT VOLTAGE 220-230 V	4,8 A
MAX. PRODUCTIVITY	6,5 M ³ /H
MAX. LIFTING HEIGHT	44 M
MAX. IMMERSION DEPTH	7 M
PUMPED LIQUID TEMPERATURE	1-35 °C
MAX. PERCENTAGE OF INSOLUBLE PARTICLES IN A WATER	0,2 %
MAX. Ø OF INSOLUBLE PARTICLES IN THE PUMPED WATER	0,5 MM
EXTERNAL THREAD OF THE OUTLET BRANCH PIPE	G1-1/2"
LENGTH OF THE POWER CABLE	10 M
WEIGHT	9,3 KG

SUBMERSIBLE PUMP CT35046F

- ENGINE PROTECTION
- FLOATING SWITCH

ACCESSORIES INCLUDED

Universal fitting.



1200 W

AMPERAGE AT VOLTAGE 220-230 V	4,8 A
MAX. PRODUCTIVITY	6,5 M ³ /H
MAX. LIFTING HEIGHT	44 M
MAX. IMMERSION DEPTH	7 M
PUMPED LIQUID TEMPERATURE	1-35 °C
MAX. PERCENTAGE OF INSOLUBLE PARTICLES IN A WATER	0,2 %
MAX. Ø OF INSOLUBLE PARTICLES IN THE PUMPED WATER	0,5 MM
INTERNAL THREAD OF THE OUTLET BRANCH PIPE	G1"
LENGTH OF THE POWER CABLE	10 M
WEIGHT	9,3 KG

OIL-FREE AIR COMPRESSOR

CT36090

- MANOMETER
- LCD SCREEN
- VARIABLE PRESSURE
- PRESSURE PROTECTION
- TEMPERATURE PROTECTION

AMPERAGE AT VOLTAGE 220-230 V	6.2 A
RATED SPEED	2800 MIN ⁻¹
AIR TANK CAPACITY	24 L
PRODUCTIVITY	100 L/MIN
OPERATING PRESSURE	7-8 BAR
WEIGHT	22,5 KG

SILENT MOTOR



1400 W

NEW

OIL-FREE AIR COMPRESSOR

CT36094

- MANOMETER
- LCD SCREEN
- VARIABLE PRESSURE
- PRESSURE PROTECTION
- TEMPERATURE PROTECTION

AMPERAGE AT VOLTAGE 220-230 V	12.4 A
RATED SPEED	2800 MIN ⁻¹
AIR TANK CAPACITY	50 L
PRODUCTIVITY	200 L/MIN
OPERATING PRESSURE	8 BAR
WEIGHT	37 KG

SILENT MOTOR



2800 W

NEW

OIL-FREE AIR COMPRESSOR

CT36073

- MANOMETER
- VARIABLE PRESSURE
- PRESSURE PROTECTION
- TEMPERATURE PROTECTION



1.5 HP

TYRE INFLATORS

CT38150

- 1/4" THREAD OF AIR CONNECTOR

0÷12 bar



RATED INPUT VOLTAGE	230 V
RATED SPEED	2800 MIN ⁻¹
AIR TANK CAPACITY	9 L
PRODUCTIVITY	193 L/MIN
OPERATING PRESSURE	6-8 BAR
WEIGHT	15,8 KG

HOSE LENGTH	750 MM
WORKING PRESSURE	0-12 BAR
GAUGE PRESSURE RANGE	0-170 PSI
THREAD OF AIR CONNECTOR	1/4"









CUTTING, GRINDING AND DIAMOND DISCS

CUTTING DISCS

METAL

Universal cutting discs for cutting and metal working. **Flat shape.**











								
CADG-MC2522115	●		115	2,5	22,23	80 m/s	13300 min ⁻¹	10 / 50
CADG-MC2522125	●		125	2,5	22,23	80 m/s	12250 min ⁻¹	10 / 50
CADG-MC2522180	●		180	2,5	22,23	80 m/s	8500 min ⁻¹	10 / 50
CADG-MC2522230	●		230	2,5	22,23	80 m/s	6650 min ⁻¹	5 / 25

CUTTING DISCS

INOX

Thin cutting discs for cutting and stainless steel working. **Flat shape.**











								
CADG-SC1022115	●		115	1,0	22,23	80 m/s	13300 min ⁻¹	10 / 100
CADG-SC1222115	●		115	1,2	22,23	80 m/s	13300 min ⁻¹	10 / 100
CADG-SC1622115	●		115	1,6	22,23	80 m/s	13300 min ⁻¹	10 / 100
CADG-SC1022125	●		125	1,0	22,23	80 m/s	12250 min ⁻¹	10 / 100
CADG-SC1222125	●		125	1,2	22,23	80 m/s	12250 min ⁻¹	10 / 100
CADG-SC2022125	●		125	2,0	22,23	80 m/s	12250 min ⁻¹	10 / 100
CADG-SC1922230	●		230	1,9	22,23	80 m/s	6650 min ⁻¹	10 / 50

GRINDING DISCS

METAL

Universal grinding discs for grinding and metal working. **Domed shape.**











								
CADG-MG6022125		●	125	6,0	22,23	80 m/s	12250 min ⁻¹	5 / 25
CADG-MG6022180		●	180	6,0	22,23	80 m/s	8500 min ⁻¹	5 / 25
CADG-MG6022230		●	230	6,0	22,23	80 m/s	6650 min ⁻¹	5 / 25

DIAMOND CUTTING DISCS

STONE - CONCRETE - MARBLE

Universal segmented diamond cutting discs. **Dry cutting.**



								
CADD-US22230			230	2,4	22,23	80 m/s	6650 min ⁻¹	5 / 25



SABRE SAW BLADES

SABRE SAW BLADES

WOOD

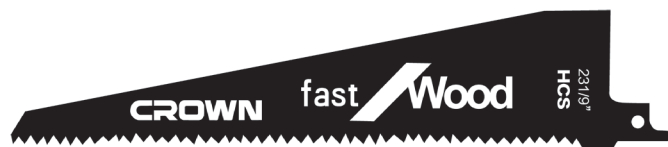
3 pcs set Sabre saw blades for complete wood processing. Made of HCS.



						
CTSSP0005	231	45	4,23	5-175	5-174	3

SABRE SAW BLADES

METAL

5 pcs set Sabre saw blades for complete metal processing. Made of BIM.



						
CTSSP0002	228	18	1	0,7-3	5-175	5

SANDING PAPERS AND BASE PLATES FOR ROTARY SANDERS



SANDING PAPERS

ROTARY SANDERS

Sanding paper, 8 holes. Velcro system.

MADE IN ITALY



			
CAP-R125A40	125	40	50
CAP-R125A60	125	60	50
CAP-R125A80	125	80	50
CAP-R125A120	125	120	50
CAP-R125A180	125	180	50



SANDING PAPERS

ROTARY SANDERS

Sanding paper, 17 holes. Velcro system.

MADE IN ITALY



			
CAP-R150A40	150	40	50
CAP-R150A60	150	60	50
CAP-R150A80	150	80	50
CAP-R150A120	150	120	50
CAP-R150A180	150	180	50



BASE PLATES

ROTARY SANDERS

Base plate for rotary sanders. Velcro system.

MADE IN ITALY



	Compatible with		Holes N°	
CSP-P13394	CT13394	125	8	1
CSP-P13395	CT13395	150	8	1
CSP-P13560	CT13560V	125	8	1

SANDING PAPERS AND BASE PLATES FOR ORBITAL SANDERS

SANDING PAPERS

ORBITAL SANDERS

Sanding paper, 17 holes. Clamping system.

MADE IN ITALY



	L mm	W mm		
CAP-S115280A40	280	115	40	50
CAP-S115280A60	280	115	60	50
CAP-S115280A80	280	115	80	50
CAP-S115280A120	280	115	120	50
CAP-S115280A180	280	115	180	50

BLADES FOR CIRCULAR SAWS AND PLUNGE SAWS

BLADES FOR CIRCULAR SAWS

WOOD

Compatibility: CT15187-165 / CT15188-190 / CT15210-235



	∅ mm			
CAS-WD2420165	165	20	24	1
CAS-WD2420190	190	20	24	1
CAS-WD2430235	235	30	24	1

BLADES FOR PLUNGE SAWS

WOOD

Compatibility: CT15134-165



	∅ mm			
CAS-WD5020165	165	20	50	1

CARBON BRUSHES

CARBON BRUSHES

ORIGINAL SPARE PART

Carbon brushes. **2 pcs.**



	Compatible with:
CSP-CB01	CT10126C
CSP-CB02	CT11020
CSP-CB03	CT10032
CSP-CB04	CT13307 / CT13308
CSP-CB05	CT12018
CSP-CB06	CT11001
CSP-CB07	CT10049
CSP-CB08	CT15133
CSP-CB09	CT14019X
CSP-CB10	CT15134-165
CSP-CB11	CT15189 / CT15181
CSP-CB12	CT13551-110RSV
CSP-CB13	CT13502-115R / CT13502-125R
CSP-CB14	CT15187-165 / CT15188-190
CSP-CB15	CT18108
CSP-CB16	CT10128C / CT10128
CSP-CB17	CT10129 / CT10129C / CT10130C
CSP-CB18	CT13501-115R
CSP-CB19	CT13489-230S
CSP-CB20	CT15210-235
CSP-CB21	CT13500-180S / CT13500-230S
CSP-CB22	CT15212
CSP-CB23	CT13507-150
CSP-CB24	CT17010V-A
CSP-CB25	CT13506-125V
CSP-CB26	CT13499-115R / CT13499-125R CT13497-115R / CT13497-125R
CSP-CB27	CT10148

CSP-CB28	CT10113
CSP-CB29	CT10151
CSP-CB30	CT10152F
CSP-CB31	CT13394
CSP-CB32	CT13395
CSP-CB33	CT13560V
CSP-CB34	CT13588V
CSP-CB35	CT15232
CSP-CB36	CT18116 BMC
CSP-CB37	CT18118V BMC
CSP-CB38	CT18123V BMC
CSP-CB39	CT18124 BMC
CSP-CB40	CT18173M BMC
CSP-CB41	CT18180 BMC
CSP-CB42	CT42020
CSP-CB43	CT42022
CSP-CB44	CT42024
CSP-CB45	CT13302
CSP-CB46	CT13302
CSP-CB47	CT18190
CSP-CB48	CT13587
CSP-CB49	CT13528
CSP-CB50	CT11023S
CSP-CB51	CT13070
CSP-CB52	CT13295

MERIT LINK

Hardware tools and equipment

Merit Link International AG

Via Giulia 25/A
CH-6855 Stabio
Switzerland

For more information visit
WWW.CROWN-TOOLS-EU.COM



Distributed by:

